



川源(中国)机械有限公司  
GSD (China) Co., Ltd.



# JA

## 沉水喷流式曝气机

**JA Submersible jet aerator**

# JA 沉水喷流式曝气机

## JA Submersible jet aerator

### 特点 Features

#### ■ 高效率溶氧

##### High efficiency oxygen dissolving

独特的混气室设计，吸入空气量多，与水混合均匀，产生气泡细而多，溶气率高。

It has unique design for gas mixture chamber whose intake air quantity is big. Air can be mixed well with water, and it can produce minute and plenty of air bubble with high air dissolving rate.

#### ■ 充分的搅拌 Intensive mixing

叶轮产生压力经喷嘴孔口产生强劲水流与空气混合喷射，使氧在水中转移效率高，同时达到良好搅拌效果，可保持活性污泥浮游必须流速。

The pressure produced by impeller through jet hole produces forceful water flow, which realizes jet after mixed with air to make oxygen move efficiently in water and at the same time achieve good mixing effect, which can maintain the flow rate necessary for activated sludge floating.

#### ■ 安静无噪音 Quiet and noise-free

本机组设计水中运转方式，低回转数、低噪音：陆上空气进气导管可加装消音设备，此外无须其他消音室设备，降低成本。

The machine unit is designed to run in water with low winding number and low noise: overland air-intake duct can be additionally equipped with silencing equipment. Cost can be reduced since no other anechoic room is required.

#### ■ 易安装维护

##### Easy for installation and maintenance

自动着脱装置与不附着脱装置二种可供选择，安装简单维护容易，节省操作费用。

There are two types for your selection: equipped with or without automatic attach device. Easy for installation and maintenance, saving operation cost.

#### ■ 适用范围广 Wide range of service

使用范围用途广，工业污水处理，畜牧业排水处理，一般污水下水道曝气工程，使用活性污泥法处理工厂排水设施之曝气槽，单独使用或组合使用皆可。

It is widely used in industrial wastewater treatment, effluent treatment of livestock husbandry and general foul sewer aeration engineering, aeration tank of effluent facilities of factory applied with activated sludge method. It can be used either individually or in a combined way.



### 构造说明 Constructive specification

本沉水喷流曝气机使用曝气设计专用泵，与气泡产生部和自动着脱装置组成一体。

This submersible jet aerator adopts specially designed aeration pump, which forms the integral unit with air bubble generating section and automatic attach device.

#### ■ 曝气专用泵 Special aeration pump

曝气设计专用泵，使用不阻塞污物型高效能叶轮，不阻塞、寿命长。

Special aeration pump uses high-performance impeller, which does not block fouls. Therefore, it has long service life.

#### ■ 气泡产生部

##### Air bubble generating section

由进气导管、喷嘴座、混气室、扩散管所组成，水流经连接于泵出口之喷嘴座高速射入混气室，空气由进气导管引导至混气室与水流结合，经扩散管排出。

This section is composed of air-inlet duct, nozzle holder, gas mixture chamber and divergent pipe. Water is pumped into gas mixture chamber at high speed from nozzle holder connected to pump outlet. Air is inducted into gas mixture chamber through air-inlet duct and is mixed with water flow, then exhausted through divergent pipe.

#### ■ 自动着脱装置 Automatic attach device

由引导管、引导板、着脱本体所组成，当机组维护时，可依着脱装置直接将泵浦从水中经引导管至槽外。

This equipment is composed of induction duct, directing plate, the attach- unit. During maintenance of equipment, the pump can be directly pulled out from water through induction duct along with the attach device.



## 结构简图及材质 Construction and material

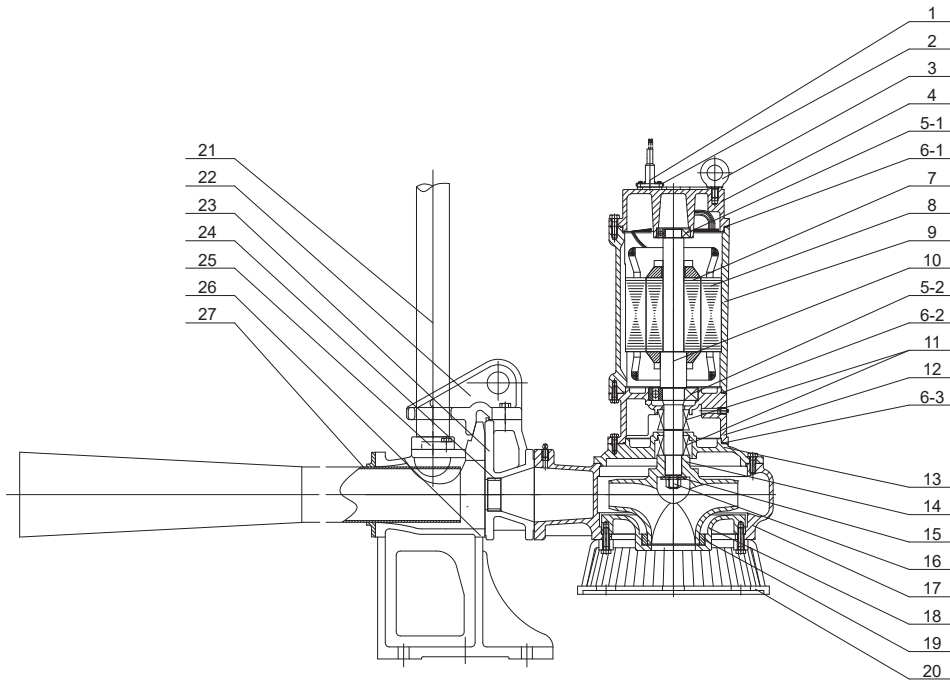

NO.	名称 Name	材质 Material	
		GB	JIS
1	水密头电缆 Watertight cable	橡胶	
2	电缆压盖 Sealing equipment of cable	06Cr19Ni10	SUS304
3	吊环 Flying ring		
4	马达盖 Motor cover	HT200	FC200
5	轴承 Bearing		
6	O型圈 O-ring	橡胶	
7	转子 Rotor		
8	定子 Stator		
9	马达本体 Motor casing	HT200	FC200
10	主轴 Shaft	20Cr13	SUS420J1
11	机械密封 Mechanical seal		
12	中承座 Bracket	HT200	FC200
13	油箱盖 Oil tank cap	HT200	FC200
14	叶轮 Impeller	HT200	FC200

NO.	名称 Name	材质 Material	
		GB	JIS
15	止退垫圈 Locked spacer	06Cr19Ni10	SUS304
16	叶轮螺母 Impeller nut	06Cr19Ni10	SUS304
17	泵体 Pump casing	HT200	FC200
18	泵体底盖 Bottom cover	HT200	FC200
19	密封环 Sealing ring		
20	滤底座 Strainer	HT200	FC200
21	进气管 Air intake pipe		
22	引导板 Directing plate	HT200	FC200
23	喷嘴座 Nozzle holder	HT200	FC200
24	喷嘴套管 Nozzle sleeve	06Cr19Ni10	SUS304
25	元宝法兰 Shoe-shaped flange	HT200	FC200
26	着脱架 Attach device	HT200	FC200
27	喷管 Divergent pipe	06Cr19Ni10	SUS304

## 性能曲线 Performance curves

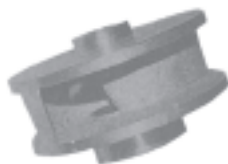

不阻塞污物型高效能叶轮  
High-performance  
impeller, without blocking fouls

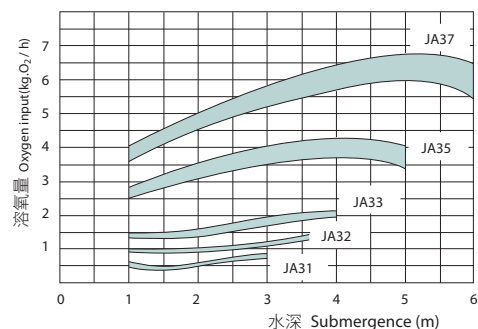
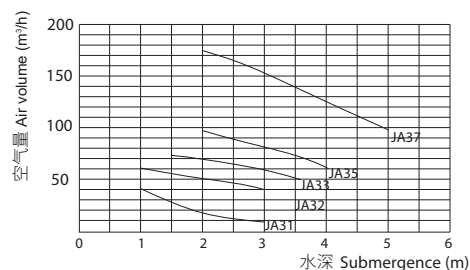

## 性能规格表 Specifications

型号 Type	功率 Power		极数 Pole	空气量-水深 Air capacity-water depth m <sup>3</sup> /h-m	供氧量 Oxygen transfer capacity kg.O <sub>2</sub> /h	曝气槽尺寸 Basin dimensions			适合水深 Workable water depth (m)
	hp	kW				L(m)	W(m)	H(m)	
JA31-50	1	0.75	4	16-2	0.35-0.45	3	2	4	1-3
JA32-80	2	1.5	4	40-3	1.0-1.2	4	3.5	4	1-3
JA33-80	3	2.2	4	60-3	1.75-1.95	5	5	4.5	1.5-3.5
JA35-100	5.5	4	4	80-3	3.5-3.95	6	6	5	2-4
JA37-100	7.5	5.5	4	155-3	5.3-5.9	7	7	6	2-5

## 无着脱式外形尺寸 Dimensions (without autsetter)

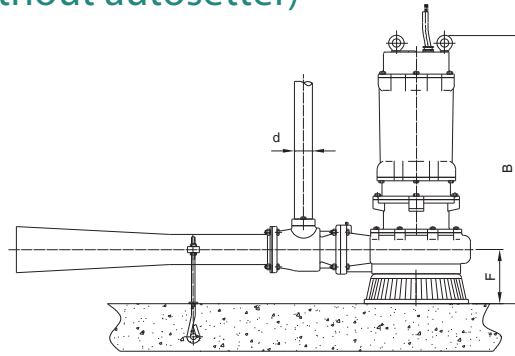
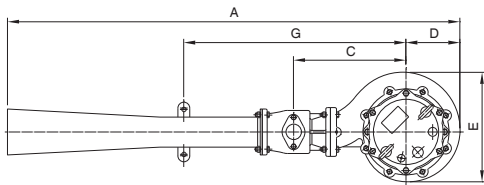

型号 Type	尺寸 Dimensions(mm)								重量 Weight (kg)
	A	B	C	D	E	F	G	d	
JA31-50	1099	597	246	135	270	129	556	DN32	55
JA32-80	1343	642	319	153	308	145	669	DN40	81
JA33-80	1343	719	319	153	308	145	669	DN40	103

型号 Type	尺寸 Dimensions(mm)								重量 Weight (kg)
	A	B	C	D	E	F	G	d	
JA35-100	1526	770	379	182	376	182	749	DN50	141
JA37-100	1526	831	379	182	376	182	749	DN50	182

## 附着脱式外形尺寸 Dimensions (with autsetter)

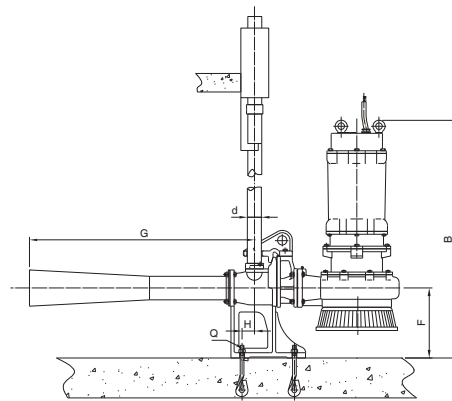
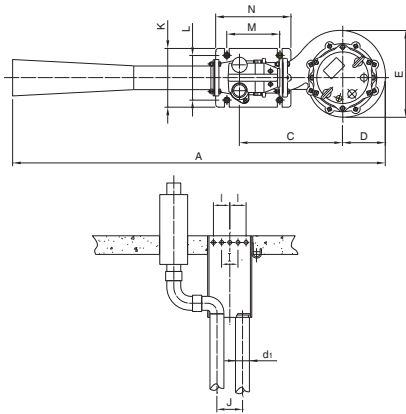

型号 Type	尺寸 Dimensions(mm)																	重量 Weight (kg)
	A	B	C	D	E	F	G	H	I	J	K	L	M	N	Q	d	d <sub>1</sub>	
JA31-50	1099	718	266	135	270	250	698	34.5	100	70	180	140	155	220	M12	DN32	DN32	71
JA32-80	1384	777	360	153	308	280	871	47	70	90	220	170	190	260	M16	DN40	DN40	121
JA33-80	1384	854	360	153	308	280	871	47	70	90	220	170	190	260	M16	DN40	DN40	143
JA35-100	1586	888	439	182	376	300	965	53.5	70	110	250	190	225	320	M16	DN50	DN50	201
JA37-100	1586	949	439	182	376	300	965	53.5	70	110	250	190	225	320	M16	DN50	DN50	242



## 配置参考图 Reference diagram of configuration

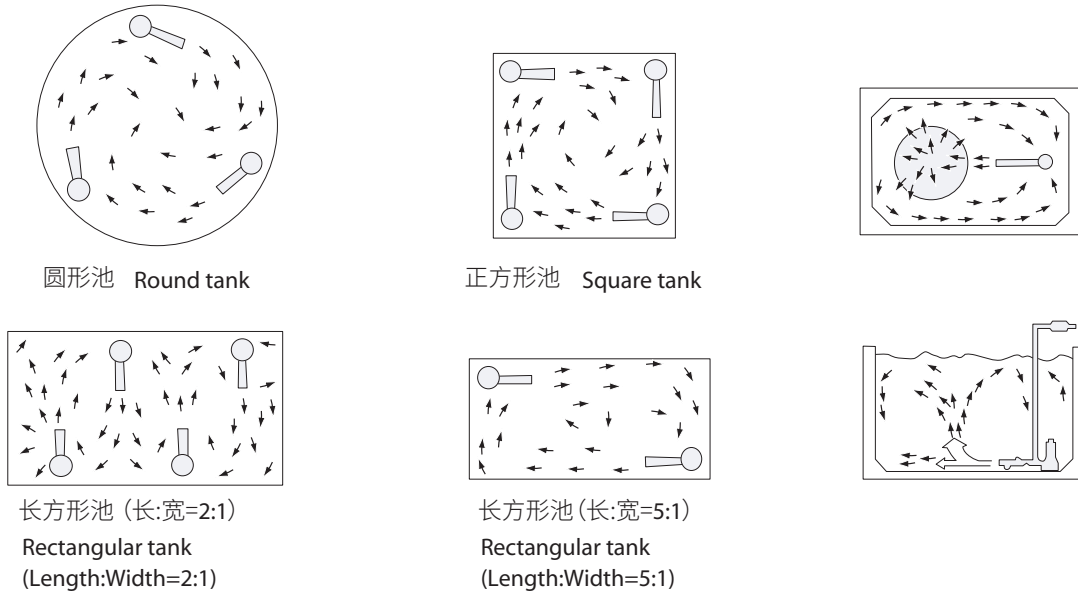

## 系统流程图 System flowchart

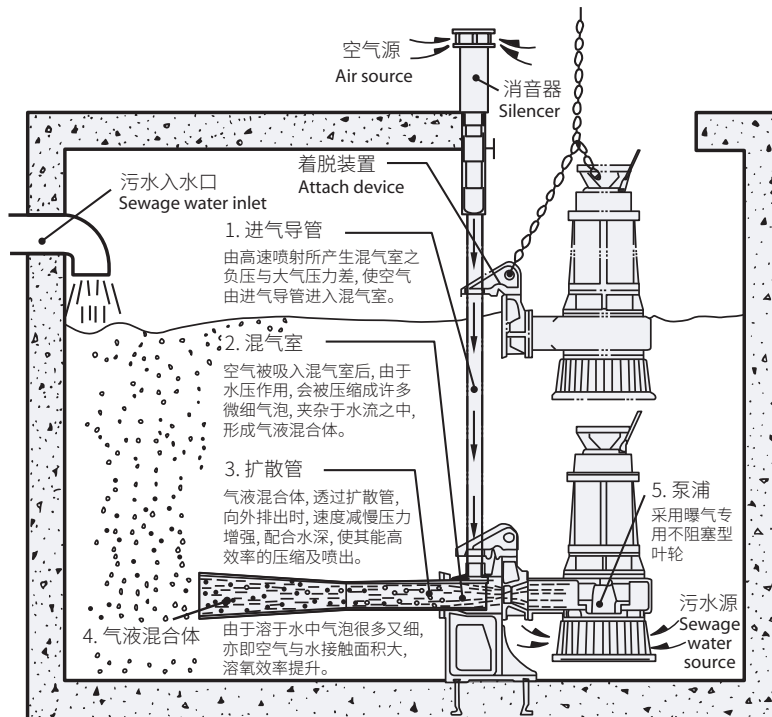

### 1. Air-intake duct

Air is taken into gas mixture chamber through air-intake duct due to the pressure difference between negative pressure in gas mixture chamber caused by high-velocity jet and atmospheric pressure.

### 2. Gas mixing chamber

After being drawn into gas mixing chamber, air is compressed into plenty of air bubbles, which are mingled in water flow forming gas-liquid compound under the action of hydraulic pressure.

### 3. Divergent pipe

When gas-liquid compound is discharged outwards through divergent pipe, its flow rate will slow down and pressure will rise along with the depth of water so that it can be compressed and ejected efficiently.

### 4. Gas-liquid compound

Oxygen dissolving efficiency increases due to that there are large quantity of minute air bubbles in water; which means the contact area between air and water is large.

### 5. Pump

This pump adopts special unblocking type impeller for aeration.



如蒙洽询请指示下列各项：  
For further details, please fulfill the chart below.

客户 Customer _____	承办人员 Undertaker _____
工程名称 Name of project _____	工程地点 Address of project _____
电话 Telephone _____	传真 Fax _____

当地状况 Local condition	海拔 (m) Elevation		最高相对湿度 (%) Max relative humidity	
	当地大气压力 (MPa) Local atmospheric pressure		最高气温 (°C) Max air temperature	
污水情况 Water condition	污水类型 Wastewater type		处理工艺 Treatment process	
	* 曝气时间 (H/day) Aeration time		日处理量 (m³/d) Waste water daily volume	
		曝气池进水 Aerating tank Inlet	曝气池出水 Aerating tank effluent	
	COD (mg/l)			
	BOD (mg/l)			
	NH <sub>3</sub> -N (mg/l)			
	pH			
	温度 (°C) Temperature			
其他 Others				
*曝气机参数 JA's parameters	使用场所 Use location	<input type="checkbox"/> 调节池 Regulating reservoir <input type="checkbox"/> 曝气池 Aeration tank <input type="checkbox"/> 其他 Others		
	空气量 (m³/min) Air capacity		溶氧量 (kgO <sub>2</sub> /h) Dissolved oxygen	
	水深 (m) Water depth		其他 Others	
*水池尺寸 Tank's dimensions	方形 Rectangle or square (m)	长 Length		
		宽 Width		
		高 Height		
	圆形 Circle (m)	直径 Diameter		
		高 Height		
其他 Others				
其它要求 Other requirements				

备注：1. 以上资料请尽可能完整填写。  
2. 项目前加注“\*”者，请务必填写。

Notes: 1. Please fill in the parameter lists as complete as possible.  
2. The item with "\*" must be filled.

本型录内容如有变更，恕不另行通知。  
We reserve the right to change content without notice.

