

如蒙洽询请指示下列各项：  
For further details, please fulfill the chart below.

客户：  
Customer \_\_\_\_\_  
工程名称：  
Name of project \_\_\_\_\_  
电话：  
Telephone \_\_\_\_\_

承办人员：  
Undertaker \_\_\_\_\_  
工程地点：  
Address of project \_\_\_\_\_  
传真：  
Fax \_\_\_\_\_

交流电源 Power	_____ V _____ Hz _____ Phase _____ KW		
当地大气环境 Local temperature	夏季 _____ °C 冬季 _____ °C		
*设备吊装方式 Ways of convey	<input type="checkbox"/> 叉车+吊车 <input type="checkbox"/> 叉车+吊卡 <input type="checkbox"/> 其它 <input type="checkbox"/> Forklift + crane <input type="checkbox"/> Forklift + elevator <input type="checkbox"/> Others		
*设备安装高度 Altitude	<input type="checkbox"/> 一楼平面安装 <input type="checkbox"/> 二楼楼板安装 <input type="checkbox"/> 其它 <input type="checkbox"/> First floor install <input type="checkbox"/> Second floor install <input type="checkbox"/> Others		
*设备安装位置 Location	<input type="checkbox"/> 标准室内安装 <input type="checkbox"/> 遮雨棚式室外安装 <input type="checkbox"/> 其它 <input type="checkbox"/> Indoor install <input type="checkbox"/> Camping outdoor install <input type="checkbox"/> Others		
*污水项目 Parameters of wastewater	类别 Type	产生量 (m <sup>3</sup> /day) Flux	
	处理时间 (Hrs/day) Time Treatment		
	处理方式 Methods	<input type="checkbox"/> 生物处理 <input type="checkbox"/> 化学处理 <input type="checkbox"/> 生物+化学处理 <input type="checkbox"/> 其它 <input type="checkbox"/> Biotreatment <input type="checkbox"/> Chemical treatment <input type="checkbox"/> Bio + Chemical treatment <input type="checkbox"/> Others	
*污泥项目 Parameters of sludge	污泥产生量 (m <sup>3</sup> /day) Capacity produced	固形物浓度 (%) S.S	
	操作时间 (Hrs/day) Time treatment	PH值:	
	腐蚀性成分含量: Corrosive component content	温度 (°C) Temperature	
	油脂含量 Grease content	<input type="checkbox"/> 无 <input type="checkbox"/> 有含油量 (%) <input type="checkbox"/> No <input type="checkbox"/> Yes Content (%)	
	来源位置 Source of sludge	<input type="checkbox"/> 污泥槽 <input type="checkbox"/> 浓缩槽 <input type="checkbox"/> 沉淀槽 <input type="checkbox"/> 浮除槽 <input type="checkbox"/> Sludge sump <input type="checkbox"/> Concentrated tank <input type="checkbox"/> Sedimentation tank <input type="checkbox"/> Flotation	
	输送方式 Transportation methods	<input type="checkbox"/> 螺杆泵 <input type="checkbox"/> 气动隔膜泵 <input type="checkbox"/> 其它 <input type="checkbox"/> Screw pump <input type="checkbox"/> Pneumatic diaphragm pump <input type="checkbox"/> Others	
	调理方式 Sludge conditioning methods	<input type="checkbox"/> 添加一种絮凝剂 <input type="checkbox"/> 添加二种絮凝剂 <input type="checkbox"/> 添加混凝剂与絮凝剂 <input type="checkbox"/> Adding one flocculant <input type="checkbox"/> Adding two flocculant <input type="checkbox"/> Adding coagulator and flocculant	
污泥槽搅拌方式 Agitating methods	<input type="checkbox"/> 无 <input type="checkbox"/> 搅拌机 <input type="checkbox"/> 搅拌泵 <input type="checkbox"/> 粗气泡散气盘 <input type="checkbox"/> 其它 <input type="checkbox"/> No <input type="checkbox"/> Mixer <input type="checkbox"/> Agitating pump <input type="checkbox"/> Disc diffuser with big air bubbles <input type="checkbox"/> Others		
*压滤机系统配置 Pressure filter system configuration	外观颜色 Appearance color	<input type="checkbox"/> 标准型 <input type="checkbox"/> Standard (silver)	
	滤板压紧方式及开板方式 Chamber plate's compressed way and plate open type	<input type="checkbox"/> 手动式油压/人工拉取逐一开板 <input type="checkbox"/> Manual oil pressure/ Manual plate-open by hand <input type="checkbox"/> 自动式油压/人工拉取手动逐一开板 <input type="checkbox"/> Auto oil pressure/ Manual plate-open by hand <input type="checkbox"/> 自动式油压/链条式人工拉取分次分段自动 <input type="checkbox"/> Auto oil pressure/ chain type multi-time plate open <input type="checkbox"/> 自动式油压/链条式二次分段快速自动开板 <input type="checkbox"/> Auto oil pressure/Chain type two-time plate open automatically <input type="checkbox"/> 自动式油压/机械式多板分段快速自动开板 <input type="checkbox"/> Auto oil pressure/ Mechanical type quickly multi-plate-open series <input type="checkbox"/> 自动式油压/机械式逐一定位自动开板 <input type="checkbox"/> Auto oil pressure/ Mechanical type plate-open automatic one by one	
	滤板形式 Plate type	<input type="checkbox"/> 单板厢式滤板 <input type="checkbox"/> 高压型单板厢式滤板 <input type="checkbox"/> 高压隔膜式滤板 <input type="checkbox"/> Chamber plate <input type="checkbox"/> High pressure chamber plate <input type="checkbox"/> High pressure membrane plate	
	滤板规格 Plate Scale	<input type="checkbox"/> 过滤面积 M <sup>2</sup> <input type="checkbox"/> 滤板尺寸 mm <input type="checkbox"/> Filter area M <sup>2</sup> <input type="checkbox"/> Plate size mm	
	落料型式 Banking type	<input type="checkbox"/> 裸空型式 <input type="checkbox"/> 漏斗集中型式 <input type="checkbox"/> 推车型式 <input type="checkbox"/> 输送带型式 <input type="checkbox"/> 自动档水盘型式 <input type="checkbox"/> Naked type <input type="checkbox"/> Hopper type <input type="checkbox"/> Container with trolley type <input type="checkbox"/> Conveyer type <input type="checkbox"/> Auto-filtereguard type	
	其他配置要求 Other requires	(相关选配要求请参照周边附属配备表) (Other optional accessories can be find on peripheral accessories chart )	
	零件备品 Spare parts	<input type="checkbox"/> 暂无需要 <input type="checkbox"/> 需要 <input type="checkbox"/> No <input type="checkbox"/> Need	
其它补充说明 Any appendix	(可另附页) (Can attached another page)		

备注：1. 以上资料请尽可能完整填写。  
2. 项目前加注“\*”者，请务必填写。

Notes: 1. Please fill in the parameter lists as complete as possible.  
2. The item with "\*" must be filled.

本型录内容如有变更，恕不另行通知。  
We reserve the right to change content without notice.





川源(中国)机械有限公司  
GSD (China) Co., Ltd.



# GC/GH/GM

## 厢式压滤脱水机系列

**GC/GH/GM frame filter press**

# GC/GH/GM 厢式压滤脱水机系列

## GC/GH/GM frame filter press

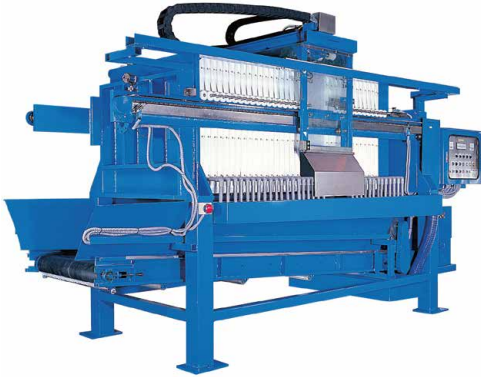

### 用途

- 各种工业废水无机性混凝沉淀之污泥脱水处理。
- 施工泥浆、河川（水库）淤泥脱水处理。
- 食品、制药、化工、染（颜）料、陶瓷、矿业及其他相关工业制程中固/液分离脱水处理。

### 特点

- 主机本体前、中、后板及横梁杆皆经CNC铣床加工后一体成型，确保机架主机体角度垂直及表面精确平整。
- 横梁杆采用碳钢实心钢板材质，配合前、后板以凸凹槽紧密契合，在H型架构后打入斜销及螺栓固定，施以高张力焊条牢固，永无焊接撕裂之虑，确保机台使用寿命长久。
- P.P工程塑胶厢式滤板，经加工成型，质量轻、耐化学性佳、过滤速度快、密封性良好、坚固耐用不变形，使用寿命长。
- 膜片式二次压滤板，可再次降低滤饼含水率及缩短处理时间，经济效益高。
- 滤布以P.P材质为主，透水性佳，滤饼剥离性强，另有多种不同材质及密度可配合各行业选择使用。
- 机械式分段快速自动开板：针对30片以上之机型快速开板，分为3~16次不等数自动开板（限GC2A/GH2A/GM2A使用）。
- 震（晃）动辅助落料系统：采用逐一震落（限NGC3/GH3/GM3）或采用一次全段晃落（限GC2/GH2/GM2系列）。
- 同步开板装置：缩短开板时间，操作简单，增加处理效率（限GC2/GH2/GM2二次分段半自动开板型式使用）。

### Application

- The various industrial waste water, inorganic, mixing-sedimentary waste slurry dehydrating treatment.
- Construction mud, river (reservoir) mud's dehydrating treatment.
- Food, pharmacy, chemical industry, dye (pigment), ceramic mining and the relative industrial process, solid and liquid separation dehydrating treatment.

### Features

- The body frame (Including the front, middle, rear and sidebars' steel-plates) worked by CNC milling machine in one and confirmed the perpendicular angle, surface leveling of the body frame accurately.
- The sidebars adopted the material of carbon steel, primarily matched by the taper dowels and blots with the front-plate, rear-plate (Convex and concave method each other). Meanwhile, used the high-tension welding rod to fix them for confirming the long life span of the machine.
- The chamber plates adopted the material of P.P engineering plastics worked by CNC milling machine in one, light quality, good resistance to chemicals, durable and unchanged shape, long using life span.
- If adopted the membrane plates may decrease the water content's rate of the sludge cake and shortened the treating time, had the high economic efficiency.
- Filter-cloth adopted the P.P material, good water permeability, strong cake-peeling property, the different and various materials of the filter-cloth for our client's choice.
- Mechanic type quickly multi-plate-open automatically one by one system: for over 30 pieces mechanic type quickly multi-plate-open automatically and plate-open from 3 to 16 times each (For GC2A/GH2A/GM2A series only).
- Cake-down vibration-assisting system: One is cake-down vibration-assisting one by one (For NGC3/GH3/GM3 series only), the other is cake-down vibration-assisting all in one (For GC2/GH2/GM2 series only).
- Simultaneous plate-open system: plate open, manpower-operation reduced and adding treatment efficiency (For GC2/GH2/GM2 series chain type semi-automatic plate-open multitime only).



## 污泥处理流程参考图 Treatment flowchart

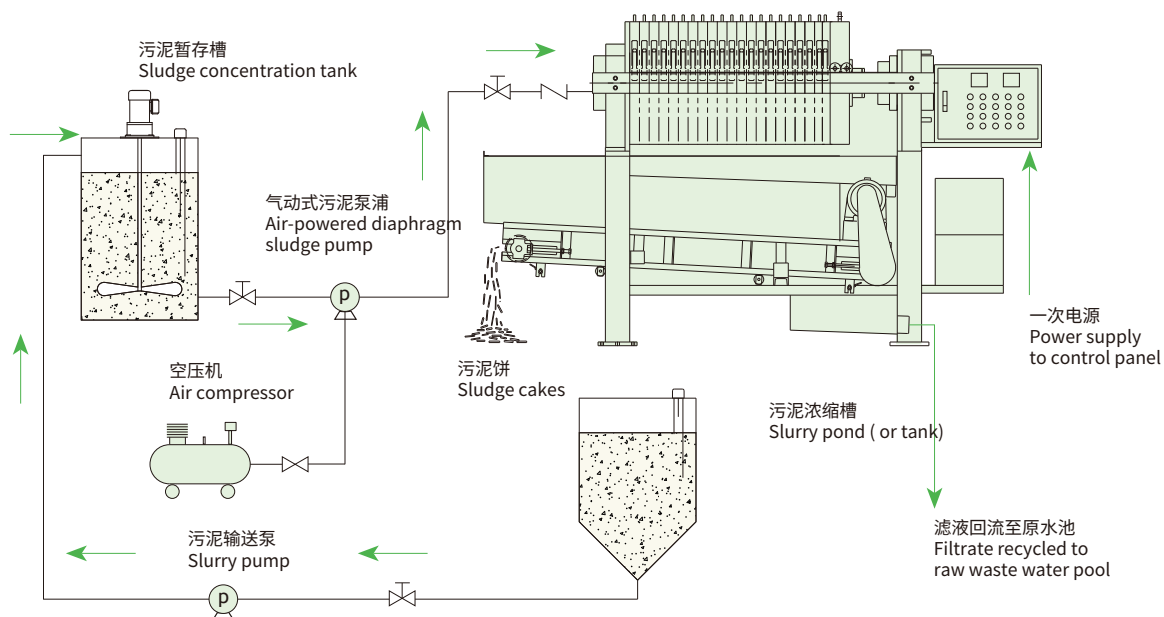

## 各种落料型式图形说明

## The diagram description of the several machine cake-down type

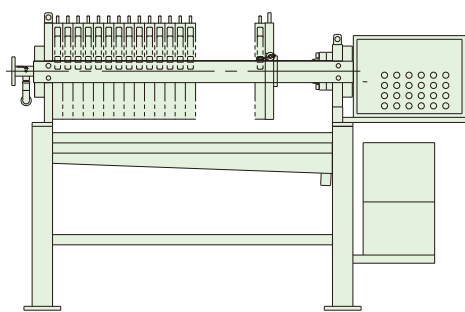

裸空型式 (Naked type)

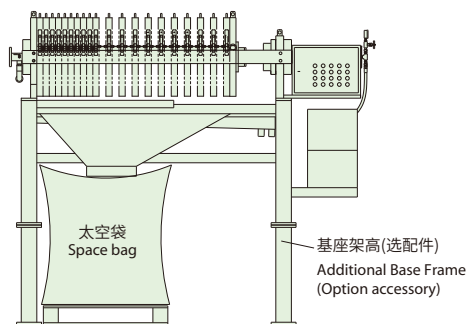

漏斗集中型式 (Hopper type)

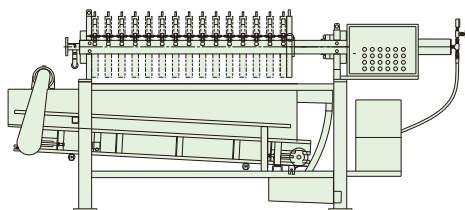

输送带型式 (Conveyor type)

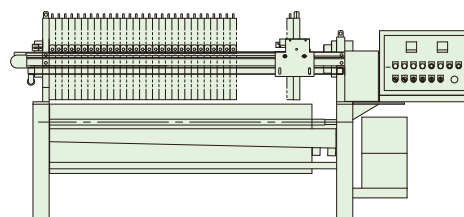

自动挡水盘型式 (Auto-filtrateguard type)



## 各机型定义、开板型式、滤板材质及落料型式说明表

The description of the various model's operation method, plate-open, filter Plate and cake-down collocation type

机型 Model	型式定义 Operation method	开板型式 Plate-open type	滤板材质/型式 Filter plate material/type	落料承接型式 Machine type				设计进料 最高压力 (kg/cm <sup>2</sup> ) Max.pressure of feed design (kg/cm <sup>2</sup> )	滤饼含水率 (%) (须视物料种类而定) Water content's rate of sludge cake(%) (depends on sludge features)
				裸空 (附手动挡水盘) Naked type (with manual filtrateguard)	漏斗集中 (附手动挡水盘) Hopper type (with manual filtrateguard)	输送带 Conveyor type	自动挡水盘 Auto- filtrateguard		
GC0系列 GC0 series	手动型 Manual	手动 (人工拉取) Manual type (plate-open by hand)	⊙ PP/厢式板 PP/chamber plate	⊙	√	×	×	7	55-78
GC1系列 GC1 series	半自动型 Semi-auto			√	⊙			8	40-78
GC2-分次系列 GC2-multi-time plate-one series	半自动型 Semi-auto	半自动 (链条式人工分次分段) Semi-auto type (Chain type multi-time plate-open)	⊙ PP/厢式板 PP/chamber plate	×	⊙	√	√	8	40-78
GC2系列 GC2 series	自动型 Auto	自动 (链条式一次全段快开) ST: 链条式二次分段快开 Auto Type (Chain type one-time quickly plate-open) ST:Chain type two-time quickly plate-open	⊙ PP/厢式板 PP/chamber plate	×	⊙	√	√	8	40-78
GC2-A系列 GC2-A series	自动型 Auto	自动 (机械式多板分段快开) Auto type (quickly multi-plate-open one by one)	⊙ PP/厢式板 PP/chamber plate	×	√	⊙	√	8	40-78
GC3系列 GC3 series	全自动型 Full-auto	自动 (机械式逐一) Auto type (plate-open one by one)	⊙ PP/厢式板 PP/chamber plate	×	√	⊙	√	8	40-78
GH/GM系列 GH/GM series	视选型而定 Depend on the actual requirements	自动 (视选型而定) Auto type (depend on the actual requirements)	PP厢式板/PP膜片/橡胶膜片 (视选型而定) PP chamber plate/PP membrane plate /rubber membrane plate (depend on the actual requirements)	×	√	⊙	√	GH=12 GM=8 or 16 (二次压) 12 for GH series 8 or 16 for GM series (2nd squeezing type)	25-72

注:

1. ⊙ 标准配备 / √ 可选购配备 / × 不可选购配备 (无此功能)。
2. 机台型式只能选其中一型。
3. 规格外型需求接受订制。
4. 本公司保留设计变更之权利。

Remark:

1. ⊙ Standard / √ Available / × Unavailable (i.e.without this function).
- 2.The machine type will be selected by one only.
- 3.The special requirement as our company can be changed is available.
- 4.We will reserve the modifying right of the above design.



## GC0手动型系列(微小量及实验室专用)

### GC0 manual type series (for small treating capacity and laboratory using)

#### 规格表 Specification sheets

##### 手动式油压/人工拉取手动逐一开板

##### Manual hydraulic type / manual plate-open by hand

机型 Model	滤板尺寸及数量 (mm / 片) Filter plate size & Q'ty (mm / PC)	总过滤面积 Filter area (m <sup>2</sup> )	总处理容量 (滤饼容积) (L / 批次) Treating ability (sludge-cake capacity) (L / Lot)	外型参考尺寸 (以裸空型式计) L × W × H Ref. machine size (naked type) (mm)	参考重量 Ref. Weight (kg)
GC0-30-5	300 × 5	0.5	4	1230×780×1330	270
GC0-30-10	300 × 10	1.2	10	1430×780×1330	300
GC0-30-15	300 × 15	1.8	15	1630×780×1330	320
GC0-30-20	300 × 20	2.5	21	1830×780×1330	350
GC0-47-10	470 × 10	3.2	36	1630×890×1480	610
GC0-47-15	470 × 15	4.9	56	1880×890×1480	670
GC0-47-20	470 × 20	6.7	76	2130×890×1480	730
GC0-47-30	470 × 30	10.2	116	2630×890×1480	840

注:

1. 本机可搭配裸空/漏斗集中/桶车...型式提供选择使用。
2. 滤板材质为P.P工程塑胶。
3. 以上规格外接受订制, 本公司保留设计变更之权利。

Remark:

1. Available for naked type / hopper type / container with trolley type...etc. Application choice.
2. Filter plate material P.P. engineering plastics.
3. Our company will reserve the right of the above design modification and accept customer's specific specifications order-made.

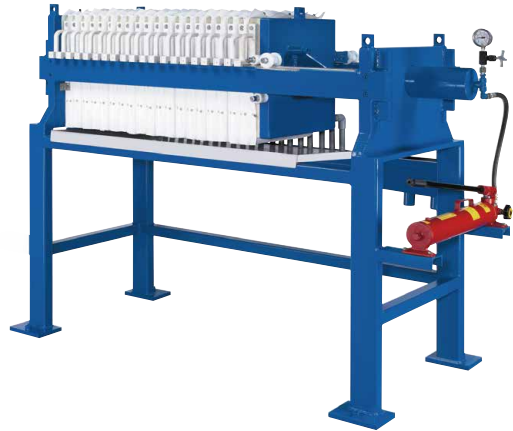

## GC1半自动型系列

### GC1 semi-auto type series

#### 规格表 Specification sheets

##### 自动式油压/人工拉取手动逐一开板

##### Auto hydraulic type / manual plate-open by hand

机型 Model	滤板尺寸及数量 (mm / 片) Filter plate size & Q'ty (mm / PC)	总过滤面积 Filter Area (m <sup>2</sup> )	总处理容量 (滤饼容积) (L / 批次) Treating ability (sludge-cake capacity) (L / Lot)	外型参考尺寸 (以漏斗集中型式计) (不含基座架高) L × W × H Ref. machine size (hopper type) (not included base frame height) (mm)	参考重量 Ref. Weight (kg)
GC1-30-10	300 × 10	1.2	10	1630 × 760 × 1370	440
GC1-30-15	300 × 15	1.8	15	1830 × 760 × 1370	460
GC1-30-20	300 × 20	2.5	21	2030 × 760 × 1370	490
GC1-47-10	470 × 10	3.2	36	2020 × 890 × 1480	750
GC1-47-15	470 × 15	4.9	56	2270 × 890 × 1480	830
GC1-47-20	470 × 20	6.7	76	2520 × 890 × 1480	880
GC1-47-30	470 × 30	10.2	116	3020 × 890 × 1480	1010
GC1-47-40	470 × 40	13.7	156	3540 × 890 × 1480	1130
GC1-63-15	630 × 15	9.4	111	2300 × 1190 × 1750	1320
GC1-63-20	630 × 20	12.7	150	2550 × 1190 × 1750	1460
GC1-63-30	630 × 30	19.4	229	3050 × 1190 × 1750	1640
GC1-63-40	630 × 40	26.1	308	3570 × 1190 × 1750	1830
GC1-63-50	630 × 50	32.8	387	4070 × 1190 × 1750	2030
GC1-80-20	800 × 20	20.3	285	3110 × 1460 × 2130	2440
GC1-80-30	800 × 30	31.0	435	3710 × 1460 × 2130	2780
GC1-80-40	800 × 40	41.7	585	4330 × 1460 × 2130	3130
GC1-80-50	800 × 50	52.4	735	4930 × 1460 × 2130	3470
GC1-80-60	800 × 60	63.1	885	5550 × 1460 × 2130	3800
GC1-100-30	1000 × 30	49.0	702	3800 × 1740 × 2260	4310
GC1-100-40	1000 × 40	65.9	944	4420 × 1740 × 2260	4820
GC1-100-50	1000 × 50	82.8	1186	5020 × 1740 × 2260	5350
GC1-100-60	1000 × 60	99.7	1428	5640 × 1740 × 2260	5880

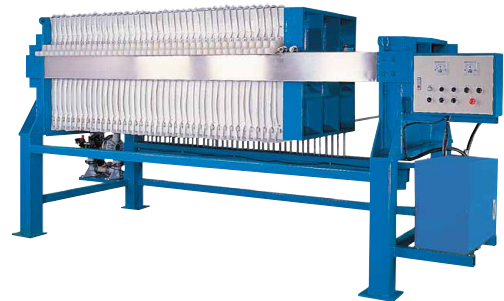

注:

1. 本机可搭配裸空/漏斗集中/桶车...型式提供选择使用。
2. 滤板材质为P.P工程塑胶。
3. 以上规格外接受订制, 本公司保留设计变更之权利。

Remark:

1. Available for naked type / hopper type / container with trolley type...etc. Application choice.
2. Filter plate material P.P. engineering plastics.
3. Our company will reserve the right of the above design modification and accept customer's specific specifications order-made.



## GC2分次半自动型系列 GC2 semi-auto type (chain type multi-time plate-open) series

规格表 Specification sheets

机型 Model	滤板尺寸及数量 (mm / 片) Filter plate size & Q'ty (mm / PC)	总过滤面积 Filter area (m <sup>2</sup> )	总处理能力 (滤饼容积) (L / 批次) Treating ability (sludge-cake capacity) (L / Lot)	外型参考尺寸 (以漏斗集中型式设计) (不含基座架高) L × W × H Ref. machine size (hopper type) (not included base frame height) (mm)	参考重量 Ref. Weight (kg)
GC2-47-15-2	470 × 15	4.9	56	2550×890×1540	810
GC2-47-20-2	470 × 20	6.7	76	3000×890×1540	890
GC2-47-30-2	470 × 30	10.2	116	4100×890×1540	1050
GC2-47-40-3	470 × 40	13.7	156	4420×890×1480	1150
GC2-63-15-2	630 × 15	9.4	111	2540×1190×1780	1430
GC2-63-20-2	630 × 20	12.7	150	2990×1190×1780	1540
GC2-63-30-2	630 × 30	19.4	229	4030×1190×1780	1790
GC2-63-40-3	630 × 40	26.1	308	4410×1190×1740	1930
GC2-63-50-4	630 × 50	32.8	387	4910×1190×1740	2100
GC2-80-15-2	800 × 15	15.0	210	2910×1460×2200	2440
GC2-80-20-2	800 × 20	20.3	285	3510×1460×2200	2670
GC2-80-30-2	800 × 30	31.0	435	4710×1460×2200	3130
GC2-80-40-3	800 × 40	41.7	585	5130×1460×2110	3410
GC2-80-50-4	800 × 50	52.4	735	5730×1460×2110	3740
GC2-80-60-5	800 × 60	63.1	885	6250×1460×2110	4050
GC2-100-15-2	1000 × 15	23.7	339	3010×1740×2280	3880
GC2-100-20-2	1000 × 20	32.1	460	3570×1740×2280	4250
GC2-100-30-2	1000 × 30	49.0	702	4770×1740×2280	4990
GC2-100-40-3	1000 × 40	65.9	944	5190×1740×2230	5450
GC2-100-50-4	1000 × 50	82.8	1186	5790×1740×2230	5990
GC2-100-60-5	1000 × 60	99.7	1428	6260×1740×2230	6490
GC2-120-20-2	1200 × 20	46.0	739	4370×2060×2620	6270
GC2-120-30-2	1200 × 30	70.2	1128	5920×2060×2620	7360
GC2-120-40-3	1200 × 40	94.4	1517	6340×2060×2540	8010
GC2-120-50-4	1200 × 50	118.6	1906	7040×2060×2540	8750
GC2-120-60-5	1200 × 60	142.8	2295	7670×2060×2540	9410
GC2-120-70-6	1200 × 70	167.0	2684	8370×2060×2540	10150
GC2-150-20-2	1500 × 20	74.5	1220	4420×2430×3280	11360
GC2-150-30-2	1500 × 30	113.7	1862	5920×2430×3280	13190
GC2-150-40-3	1500 × 40	152.9	2504	6390×2430×3200	14200
GC2-150-50-4	1500 × 50	192.1	3146	7090×2430×3200	15400
GC2-150-60-5	1500 × 60	231.3	3788	7660×2430×3200	16530
GC2-150-70-6	1500 × 70	270.5	4430	8360×2430×3200	17730

自动式油压/链条式人工分次分段半自动开板  
Auto hydraulic type / chain type semi-automatic  
plate-open multi-time



注:

1. 本机型号可搭配漏斗集中/输送带...型式提供选择使用。
2. 本机型号另有16 kg/cm<sup>2</sup>高压力注入型(型号为HGC2-××)提供选择使用(选配备),其相关数据请另洽询。
3. 滤板材质为P.P工程塑胶。
4. 以上规格外接受订制,本公司保留设计变更之权利。

Remark:

1. Available for hopper type / conveyor type...etc. Application choice.
2. We also have the high-pressure (16kg/cm<sup>2</sup>) type (model: HGC2-xx) (option) for your choice. If need the above series-products in detail, pls. Contact us directly.
3. Filter plate material: P.P. engineering plastics.
4. Our company will reserve the right of the above design modification and accept customer's specific specifications' order-made.

## GC2自动型系列 GC2 auto type series

规格表 Specification sheets

自动式油压/链条式一次全段快速自动开板

Auto hydraulic type / chain type one-time quickly plate-open

ST: 自动式油压/链条式二次分段快速自动开板

ST: Auto hydraulic type / chain type two-time quickly plate-open

机型 Model	滤板尺寸及数量 (mm / 片) Filter plate size & Q'ty (mm / PC)	总过滤面积 Filter area (m <sup>2</sup> )	总处理能力 (滤饼容积) (L / 批次) Treating ability (sludge-cake capacity) (L / Lot)	外型参考尺寸 (以漏斗集中型式设计) (不含基座架高) L × W × H Ref. machine size (hopper type) (not included base frame height) (mm)	参考重量 Ref. Weight (kg)
GC2-30-10	300 × 10	1.2	10	2270×760×1370	480
GC2-30-15	300 × 15	1.8	15	3110×760×1370	560
GC2-47-10	470 × 10	3.2	36	2380×890×1480	780
GC2-47-15	470 × 15	4.9	56	3180×890×1480	870
GC2-47-20	470 × 20	6.7	76	4030×890×1480	980
GC2-63-10	630 × 10	6.0	71	2370×1190×1750	1380
GC2-63-15	630 × 15	9.4	111	3170×1190×1750	1500
GC2-63-20	630 × 20	12.7	150	4020×1190×1750	1680
GC2-80-15	800 × 15	15.0	210	3630×1460×2130	2500
GC2-80-20	800 × 20	20.3	285	4580×1460×2130	2850
GC2-100-15	1000 × 15	23.7	339	3840×1740×2260	4050
GC2-100-20	1000 × 20	32.1	460	4790×1740×2260	4550
GC2-120-15	1200 × 15	33.9	545	4840×2030×2600	6000
GC2-120-20ST	1200 × 20	46.0	739	4520×2030×2600	6150
GC2-150-15	1500 × 15	54.9	899	4880×2390×3220	11000
GC2-150-20ST	1500 × 20	74.5	1220	4520×2390×3220	11200
GC2-200-15ST	2000 × 15	91.0	1820	5070×2920×3760	23500
GC2-200-20ST	2000 × 20	123.5	2470	6400×2920×3760	26000



注:

1. 本机型号可搭配漏斗集中/输送带/自动挡水盘...型式提供选择使用。
2. 本机型号另有16 kg/cm<sup>2</sup>高压力注入型(型号为HGC2-××)提供选择使用(选配备),其相关数据请另洽询。
3. 滤板材质为P.P工程塑胶。
4. 以上规格外接受订制,本公司保留设计变更之权利。

Remark:

1. Available for hopper type / conveyor type / auto-filtrateguard type ...etc. Application choice.
2. We also have the high-pressure (16kg/cm<sup>2</sup>) type (model: HGC2-xx) (option) for your choice. If need the above series-products in detail, pls. Contact us directly.
3. Filter plate material: P.P. engineering plastics.
4. Our company will reserve the right of the above design modification and accept customer's specific specifications' order-made.



## GC2A多板自动型系列 GC2A auto type quickly multi-plate-open series

### 规格表 Specification sheets

自动式油压/机械式多板分段快速自动开板

Auto hydraulic type / mechanic type quickly multi-plate-open automatically

机型 Model	滤板尺寸及数量 (mm / 片) Filter plate size & Q'ty (mm / PC)	总过滤面积 Filter area (m <sup>2</sup> )	总处理容量 (滤饼容积) (L / 批次) Treating ability (sludge-cake capacity) (L / Lot)	外型参考尺寸 (本尺寸以P型及输 送带式计) (不含基座架高) L × W × H Ref. machine size (P type & conveyor Type) (not included base frame height) (mm)	参考重量 Ref. Weight (kg)
GC2 - 63 - 30A3	630 × 30	19.4	229	4230×1240×1750	2280
GC2 - 63 - 40A4	630 × 40	26.1	308	4750×1240×1750	2550
GC2 - 63 - 50A5	630 × 50	32.8	387	5250×1240×1750	2820
GC2 - 80 - 30A3	800 × 30	31.0	435	4690×1510×2130	3420
GC2 - 80 - 40A4	800 × 40	41.7	585	5310×1510×2130	3860
GC2 - 80 - 50A5	800 × 50	52.4	735	5910×1510×2130	4300
GC2 - 80 - 60A6	800 × 60	63.1	885	6530×1510×2130	4740
GC2 - 100 - 30A3	1000 × 30	49.0	702	4920×1820×2260	4980
GC2 - 100 - 40A4	1000 × 40	65.9	944	5540×1820×2260	5600
GC2 - 100 - 50A5	1000 × 50	82.8	1186	6140×1820×2260	6260
GC2 - 100 - 60A6	1000 × 60	99.7	1428	6760×1820×2260	6860
GC2 - 120 - 30A5	1200 × 30	70.2	1128	5270×2130×2900	8090
GC2 - 120 - 40A6	1200 × 40	94.4	1517	5990×2130×2900	9000
GC2 - 120 - 50A7	1200 × 50	118.6	1906	6690×2130×2900	9910
GC2 - 120 - 60A9	1200 × 60	142.8	2295	7410×2130×2900	10830
GC2 - 150 - 70A10	1200 × 70	167.0	2684	8110×2130×2900	11730
GC2 - 150 - 30A5	1500 × 30	113.7	1862	5270×2510×3220	12350
GC2 - 150 - 40A6	1500 × 40	152.9	2504	5990×2510×3220	13750
GC2 - 150 - 50A7	1500 × 50	192.1	3146	6690×2510×3220	15150
GC2 - 150 - 60A9	1500 × 60	231.3	3788	7400×2510×3220	16550
GC2 - 150 - 70A10	1500 × 70	270.5	4430	8100×2510×3220	18000
GC2 - 200 - 40A8	2000 × 40	253.5	5070	7530×2960×3760	32900
GC2 - 200 - 50A10	2000 × 50	318.5	6370	8380×2960×3760	35900
GC2 - 200 - 60A12	2000 × 60	383.5	7670	9250×2960×3760	38900
GC2 - 200 - 70A14	2000 × 70	448.5	8970	10100×2960×3760	41900
GC2 - 200 - 80A16	2000 × 80	513.5	10270	10970×2960×3760	44900

注:

1. 本机型可搭配漏斗集中/输送带/自动挡水盘... 型式提供选择使用。
2. 本机型另有16 kg/cm<sup>2</sup> 高压力注入型(型号为 HGC2-××A) 提供选择使用(选配备), 其相关数据请另洽询。
3. 滤板材质为P.P工程塑胶。
4. 以上规格外接受订制, 本公司保留设计变更之权利。

Remark:

1. Available for hopper type / conveyor type / auto-filt rateguard type ...etc. Application choice.
2. We also have the high-pressure (16kg/cm<sup>2</sup>) type ( model : HGC2-××A) (option) for your choice. If need the above series-products in detail, pls. Contact us directly.
3. Filter plate material : P.P. engineering plastics.
4. Our company will reserve the right of the above design modification and accept customer' s specific specifications' order-made.





## GC3全自动型系列 GC3 full-auto type series

### 规格表 Specification sheets

自动式油压/机械式逐一定位自动开板

Auto hydraulic type / mechanic type plate-open automatic one by one

机型 Model	滤板尺寸及数量 (mm/片) Filter plate size & Q'ty (mm / PC)	总过滤面积 Filter area (m <sup>2</sup> )	总处理能力 (滤饼容积) (L / 批次) Treating ability (sludge-cake capacity) (L / Lot)	外型参考尺寸 (本尺寸以P型及输 送带式计) (不含基座架高) L × W × H Ref. machine size (P type & conveyor Type) (not included base frame height) (mm)	参考重量 Ref. Weight (kg)
GC3 - 63 - 20	630 × 20	12.7	150	3490×1540×2370	2240
GC3 - 63 - 30	630 × 30	19.4	229	3990×1540×2370	2540
GC3 - 63 - 40	630 × 40	26.1	308	4510×1540×2370	2850
GC3 - 63 - 50	630 × 50	32.8	387	5010×1540×2370	3150
GC3 - 80 - 30	800 × 30	31.0	435	4440×1810×2700	3650
GC3 - 80 - 40	800 × 40	41.7	585	5060×1810×2700	4100
GC3 - 80 - 50	800 × 50	52.4	735	5660×1810×2700	4560
GC3 - 100 - 30	1000 × 30	49.0	702	4840×2120×2780	5480
GC3 - 100 - 40	1000 × 40	65.9	944	5460×2120×2780	6170
GC3 - 100 - 50	1000 × 50	82.8	1186	6060×2120×2780	6860
GC3 - 100 - 60	1000 × 60	99.7	1428	6680×2120×2780	7560
GC3 - 120 - 30	1200 × 30	70.2	1128	5010×2280×3380	8690
GC3 - 120 - 40	1200 × 40	94.4	1517	5730×2280×3380	9600
GC3 - 120 - 50	1200 × 50	118.6	1906	6430×2280×3380	11500
GC3 - 120 - 60	1200 × 60	142.8	2295	7150×2280×3380	11430
GC3 - 120 - 70	1200 × 70	167.0	2684	8750×2280×3380	12330
GC3 - 150 - 30	1500 × 30	113.7	1862	5090×2600×3710	13050
GC3 - 150 - 40	1500 × 40	152.9	2504	5810×2600× 3710	14450
GC3 - 150 - 50	1500 × 50	192.1	3146	6510×2600×3710	15870
GC3 - 150 - 60	1500 × 60	231.3	3788	7230×2600×3710	17250
GC3 - 150 - 70	1500 × 70	270.5	4430	7930×2600×3710	18730
GC3 - 200 - 40	2000 × 40	253.5	5070	7530×3210×4250	34000
GC3 - 200 - 50	2000 × 50	318.5	6370	8380×3210×4250	36900
GC3 - 200 - 60	2000 × 60	383.5	7670	9250×3210×4250	39850
GC3 - 200 - 70	2000 × 70	448.5	8970	10100×3210×4250	42800
GC3 - 200 - 80	2000 × 80	513.5	10270	10970×3210×4250	45800

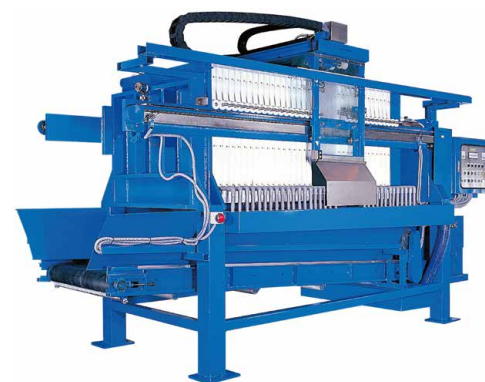

注:

1. 本机可搭配漏斗集中/输送带/自动挡水盘...型式提供选择使用。
2. 本机有以下选配功能装置:
  - ①. 低压管中逆流洗滤布 (在型号后加R)
  - ②. 高压正面清洗滤布 (在型号后加P)
 } 二选一使用
- ③. 震动辅助落料 (在型号后加V/本装置需视泥饼剥落性而定, 如有掉落不完全时须人工予以协助清除)。
3. 本机另有16 kg/cm<sup>2</sup>高压注入型 (型号为HGC3-××) 提供选择使用 (选配), 其相关数据请另洽询。
4. 滤板材质为P.P.工程塑胶。
5. 以上规格外接受订制, 本公司保留设计变更之权利。

Remark:

1. Available for hopper type / conveyor type / auto-filtrateguard type ...etc. Application choice.
2. This kind of series products have the following option function device for your choice:
  - ①. Low pressure reverse-washing filter-cloth in pipe (For example GC3-63-20R)
  - ②. High pressure positive washing filter-cloth (For example GC3-63-20P)
  - ③. If need the cake-down vibration-assisting device (For example GC3-63-20V) (Note: this device's efficiency depends on the peeling property of the cake. If the cake can not be peeled off 100%, need the operator to scrape the remaining cake.)
3. We also have the high-pressure (16kg/cm<sup>2</sup>) type (Model: HGC3-××) (Option) for your choice. If need the above series-products in detail, pls. Contact us directly.
4. Filter plate material: P.P. engineering plastics.
5. Our company will reserve the right of the above design modification and accept customer's specific specifications' order-made.



## GH系列 高压单板厢式型(P : 8 ~ 12kg/cm<sup>2</sup>)

GH series high pressure chamberplate type(p : 8 ~ 12kg/cm<sup>2</sup>)

(本系列机型需求请另洽询) (If need the above series products in detail, pls contact us directly.)

## GM系列 高压膜片式二次压型(P : 8 或 16kg/cm<sup>2</sup>)

GM series high pressure membrane type 2nd squeezing series (p : 8 or 16kg/cm<sup>2</sup>)

(本系列机型需求请另洽询) (If need the above series products in detail, pls contact us directly.)

特点 :

1. 操作时间减少约40% ~ 75%
2. 滤饼含水率约25% ~ 72%
3. 滤饼体积及后续处理成本可减少40% ~ 75%

Feature:

1. The time of operation will be shortened by 40% ~ 75%
2. The water content's rate of cake : 25% ~ 72%
3. The cake's volume and post-treating cost will be reduced by 40% ~ 75%

## 单板厢式与膜片式滤液释出情形及时效比较图

The comparison diagram of filtrate output and time

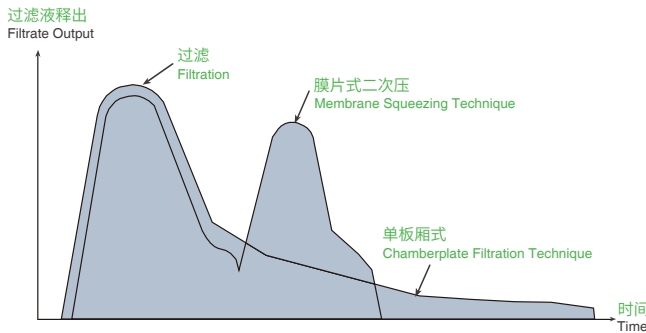

## 单板厢式与膜片式机台处理效益比较图

The comparison diagram of water content's rate and time

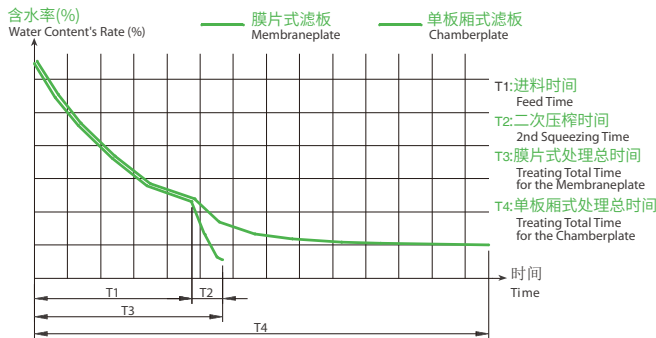

## 全膜片式滤板压榨过程

Membraneplates filtration-squeezing process

Membraneplates filtration-squeezing process

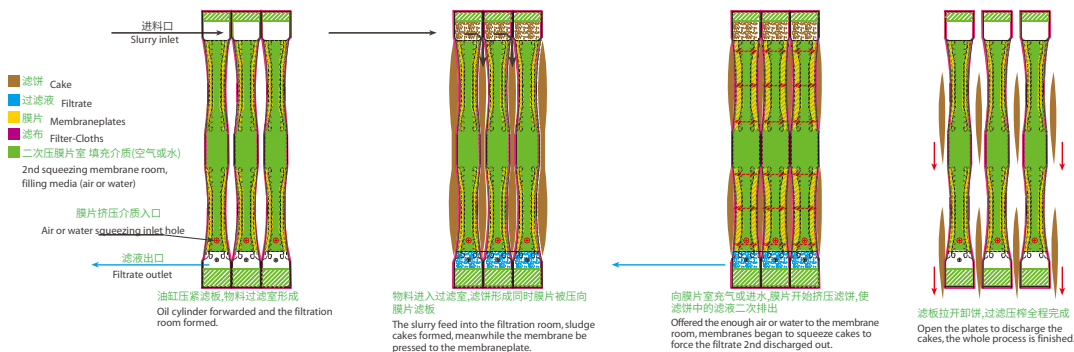

## 选购配备

### 电控装置(选购配备/请参考各机型功能说明表)

1. 采用PLC可编程控制器, 配合流程指示灯表显示功能, 易于掌握整个处理现况同时保证相关动作连续运行。
2. 可搭配人机触控界面, 动作一目了然, 操控自如。



- A. 紧急停止开关装置: (选购配备/请参考各机型功能说明表) 机台及人员操作时可紧急停机以保障安全。
- B. 完成闪灯及警报装置: (选购配备/请参考各机型功能说明表) 告知操作人员处理完成, 方便后序作业。

### 摇臂式自动高压正面清洗系统 (选购配备/请参考各机型功能说明表)

以20~40kg/cm<sup>2</sup>高压水柱正面清洗滤布, 维持良好过滤效果, 达到网孔不阻塞, 确保处理时效及降低滤饼含水率。

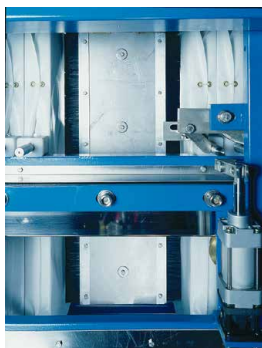

### 低压管中逆洗装置 (选购配备/请参考各机型功能说明表)

由滤布反面进行逆灌清洁以维持良好过滤效果。可藉由密闭管中灌洗, 达到水洗滤饼的目的 (一般用于化工行业)。

## Optional devices

Control panel (Optional devices, pls refer to the description of the various model's functions and accessories.)

1. Adopted PLC control with treating flowchart Indicator board, the whole treating condition controlled easily and may enlarge the relative interlink.
2. Adopted man-machine monitor touch interface for operating clearly and easily.

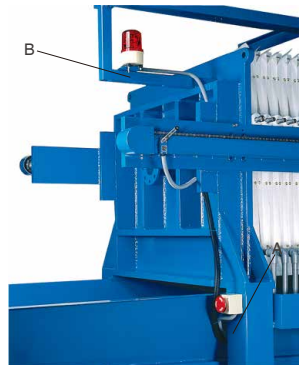

- A. Emergency stop switch device: (Optional devices, Pls refer to the description of the various model's functions and accessories.) For protecting machine and operators' safety when emergency or danger occurred.
- B. Finished flash indicator and alert device: (Optional devices, Pls refer to the description of the various model's functions and accessories.) Assist to advise the operators the treatment process finished for the next treatment process forwarding conveniently.

Arm-swing type auto-high pressure washing system (Optional devices, pls refer to the description of the various model's functions and accessories.)

Adopted the high pressure water column(P: 20~40kg/cm<sup>2</sup>)to wash the filter-cloth completely, maintained the permeability of the filter-cloth, and confirmed the treating efficiency and decreased the water content's rate of the sludge cake.

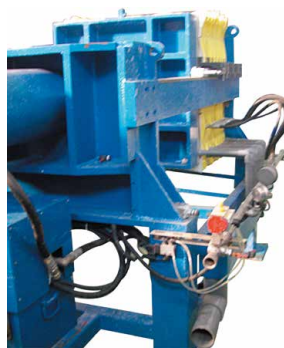

Low pressure reverse-washing filter-cloth in pipe system (Optional devices, Pls refer to the description of the various model's functions and accessories.)

Via low pressure reverse-washing filter-cloth in pipe for keeping the good filtering effect. To reach cake-washing purpose by reverse-washing in close-pipe.

## 污泥处理实例

### Sludge dewatering examples

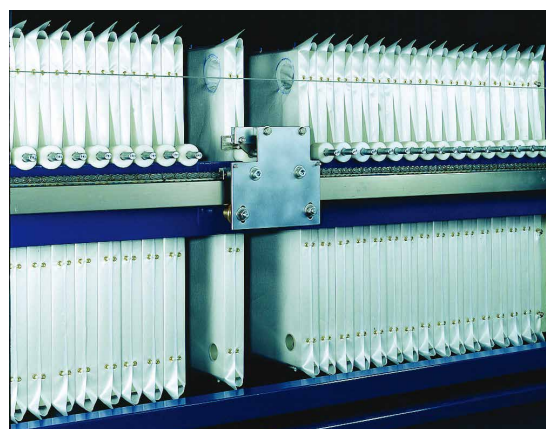

## 各机型功能说明及周边附属配备表

### The description of the various model's functions and peripheral accessories

机 型 Model	机台功能说明 Functional description											周边附属配备 Peripheral accessories		
	批次控制系统 Batch control system		完成闪灯 及 警报装置 Finished flash indicator and alert device	震动辅助 落料系统 Cake-down vibration- assisting device	紧急停止 开关装置 Emergency stop switch device	安全保证系统 (红外线电眼/红外线光 罩/紧急停止拉绳) Safekeeping system (IR electric eye / IR aligner mask / emergency stop pull-rope)	低压管中 逆洗滤布装置 Low pressure reverse washing filter-cloth in pipe	高压正面清 洗滤布装置 High pressure positive washing filter-cloth	PLC程式及 流程显示灯表 PLC control with the treating flowchart indicator board	人机触控 变频介面 Man- machine monitor touch interface	滤心回吹 功能 Core blowing function	输送带 Feed pump	空压机 (气动泵用) Air compressor vibrator (for air-powered diaphragm pump)	过滤液回流泵 (视需求而定) Filtrate recycling pump (depend on the actual requirement)
	时间计 Timer	压力差 Pressure difference												
GC0 系列 GC0 Series	×	×	×	×	×	×	×	×	×	×	√	√	√	
GC1 / GC2 分次系列 GC1 / GC2 Multi-Time Plate-Open Series	○	√	√	×	√	×	×	×	×	×	√	√	√	
GC2 系列 GC2 Series	○	√	√	√	√	√	√	×	√	√	√	√	√	
GC2-A 系列 GC2-A Series	○	√	√	×	√	√	√	×	√	√	√	√	√	
GC3 系列 GC3 Series	○	○	√	√	√	√	√	√	○	√	√	√	√	
GH / GM 系列 GH / GM Series	视选型而定 Depends on client's requirements											√	√	√

注:

1. ○ 标准配备/√ 可选购配备/× 不可选购配备(无此功能)
2. 震动辅助落料系统-须视滤饼剥离性而定, 如无法100%完全脱落时, 需人力局部协助清除。
3. 本公司保留设计变更之权利。

Remark:

1. ○ Standard/√ available/× unavailable (i.e. without this funtion)
2. Cake-down vibration-assisting device: depend on the peeling property of the cake. If the cake can not be peeled off 100%, need the operator to scrape the remaining cake.
3. Our company reserves the right of the above design modification.

