



川源(中国)机械有限公司
GSD (China) Co., Ltd.



C SERIES

可空转立式耐酸碱泵

C SERIES wet/dry running vertical chemical pump

C-SERIES 可空转立式耐酸碱泵

C SERIES wet/dry running vertical chemical pump

概述

CS/CST泵性能可靠，可广泛地应用于化学药水循环到加工模组等各种用途。即使泵浦空转也不会出现轴封或衬套损坏的问题。该泵浦可输送各种高腐蚀性的溶液，并根据选用的结构材质不同，可承受最高流体温度达75℃(167°F)到85℃(185°F)。

用途

- 化学药水或清水循环
- 废气塔/废水处理
- 电镀
- 淋湿处理
- 净化溶液
- 各种酸液输送

特点

- 泵浦材质依化学性需求不同有FRPP、PVDF、CPVC可供选择。
- 最高流体温度：
FRPP/CPVC 75℃(167°F)，PVDF 85℃(185°F)
- 高效率，低操作成本，不泄漏，易于维护。
- 耐腐蚀性优良。
- 配有持续重负载的TEFC马达。
- 泵浦空运转不会损坏干式轴封。
- 三相马达配有轴心键，可避免叶轮因马达逆转而损坏。

结构特点

- 槽内式安装，安装时一定要依安装高度之规定来操作。
- 泵头中没有轴封或轴承。
- CS--马达干式轴封
CS--120 V绝缘电线附接地
CS--1/4~2 hp泵浦座上有排气槽
CST--泵浦座上有通气槽
- 泵浦运转时，离心力使单干式轴封打开，排除磨擦及密封液体；泵浦停机时，干式轴封闭合归位，以防止酸气液体接触到马达或轴承。

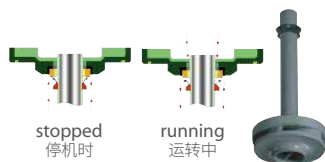

General

CS/CST pumps are with reliable performance, these pumps are used in a wide range of applications from chemical recirculation to process modules. There is no seal construction that can be damaged when the pumps run dry. CS/CST pumps can deliver the maximum fluid temperature of 167°F(75℃) to 185°F(85℃), depending on the materials of construction, and can handle the most abrasive solutions.

Applications

- Chemical or water recirculation
- Fume scrubbers/waste treatment
- Plating solutions
- Wet processing
- Cleaning solutions
- Deliver acids

Features

- CPVC, PVDF, or FRPP materials are on requests for different solutions.
- Max.fluid temperature:
FRPP/CPVC 167°F(75℃), PVDF 185°F(85℃)
- High efficiency, low operating cost, leakfree operation and easy maintenance.
- Excellent chemical resistance.
- Adopt the continous heavy-duty TEFC motor.
- CS/CST pumps can run dry without damage to dry seals.
- The pump shaft incorporates a keyed lock to the impeller in order to prevent impeller damage when 3 phase power motor runs in reverse.

Construction features

- In-tank use only.
- No seal or bearing construction.
- CS--Dry seal.
CS--120 V cord with ground.
CS--Air gap in pump base for 1/4 to 2 hp.
CST--Air gap in pump base.
- The single dry seal is opened by centrifugal force when pump is operating, this eliminates friction and seal wear. The seal closes back up when the pump shuts down to prevent vapor or liquid from reaching the motor face or bearing.

- 所有本公司三相电源的泵浦都有轴心键，当电源接反的时候，叶轮不会掉落，排除了可能对叶轮、罩壳及干式轴封的损坏。



- 除了1/8~1/6 hp之外，所有其他规格的泵浦均在泵浦座上有一个干式轴封和一个排气槽，排气槽搭配顶部的干式轴封，可防止酸气渗透到马达轴承。



- 应用于槽内安装情况下，泵浦停机时所产生的反压背流液体能从溢流孔排出。

- 此弯头部件可安装于泵出口端，配管拆解容易，依药水不同有CPVC、FRPP、PVDF材质可供选择。



- 双O环配置可确保前盖紧封且不会脱落。
- C扣环方便装卸，同时可加强对前盖支撑。

- Each 3 phase power pump from GSD is with a keyed impeller shaft that eliminates the possibility of damage to the impeller, housing or dry seal when the power is reversed, the impeller will not fall off.

- Except CS 1/8~1/6 hp, all the rest models have a slotted air gap in the pump base and a dry vapor seal, thereby preventing chemicals penetrating to the motor bearings. Dry seal on the above vented slot can safely disperse acid and alkaline vapor away from the shaft and motor bearings.

- For in-tank applications, the vent hole must be opened for back-flow to run through when pump shut down.

- This elbow-union can be connected to the outlet for easy plumbing. CPVC, FRPP, PVDF materials are available.

- Two O-rings secure the front cover tightly and never fall off.

- C-clip is easy to be assembled and giving support for the front cover.

型号说明 Type description

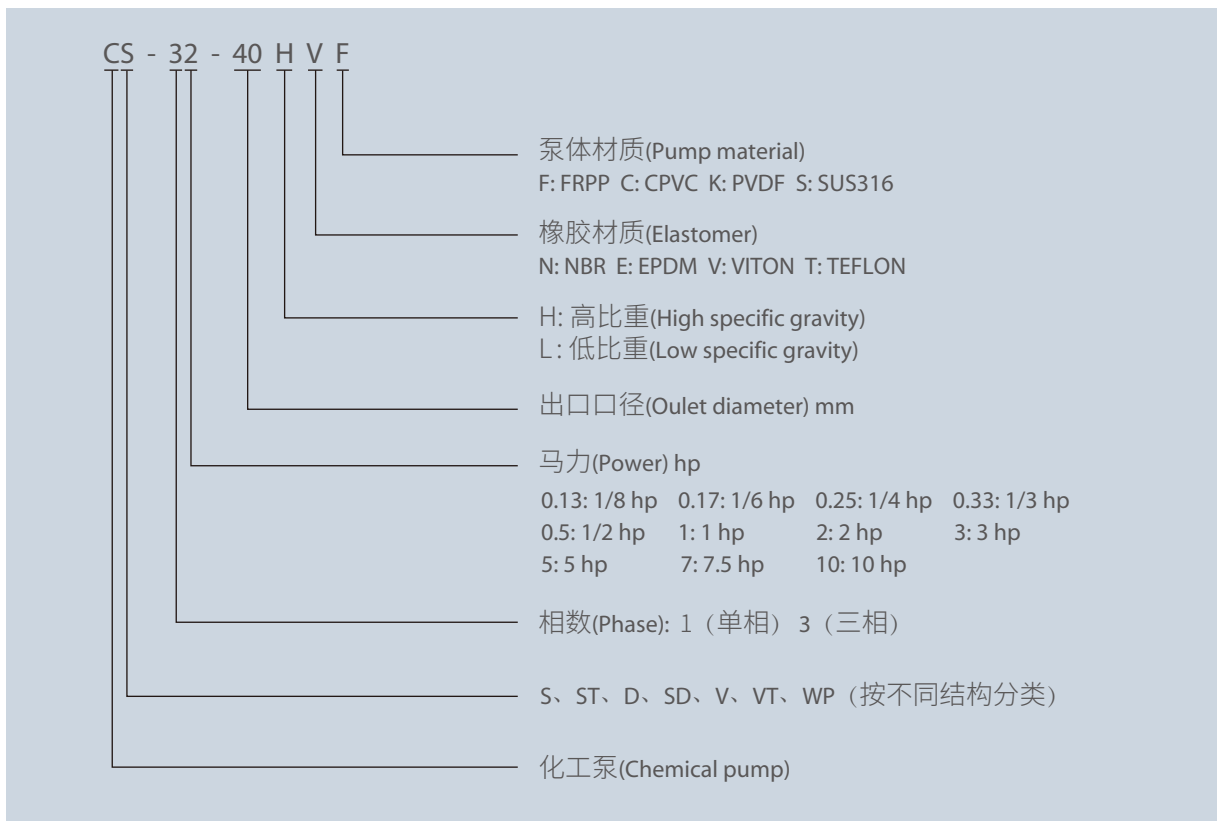

结构简图及材质 Construction and material

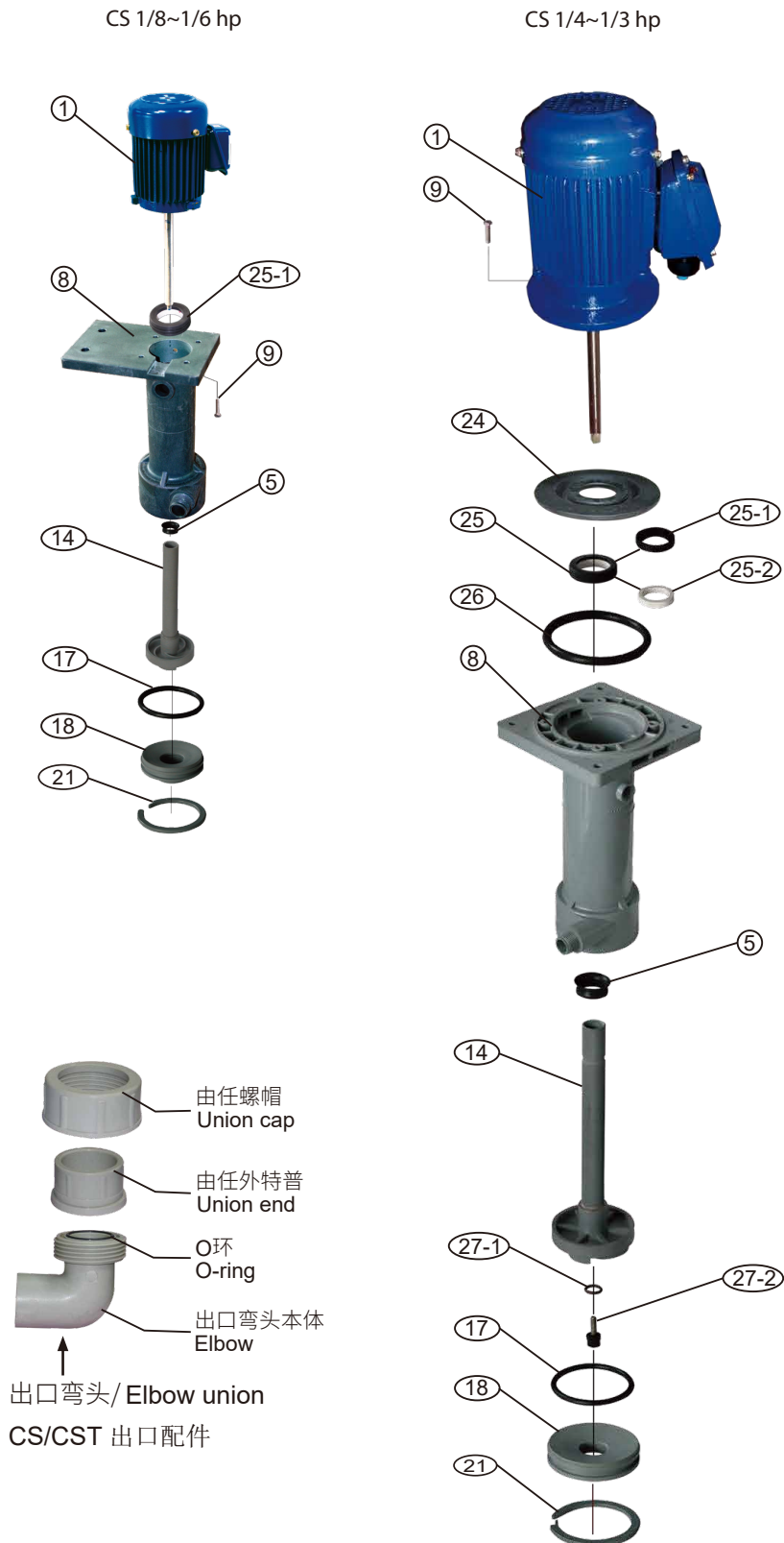

结构简图及材质 Construction and material

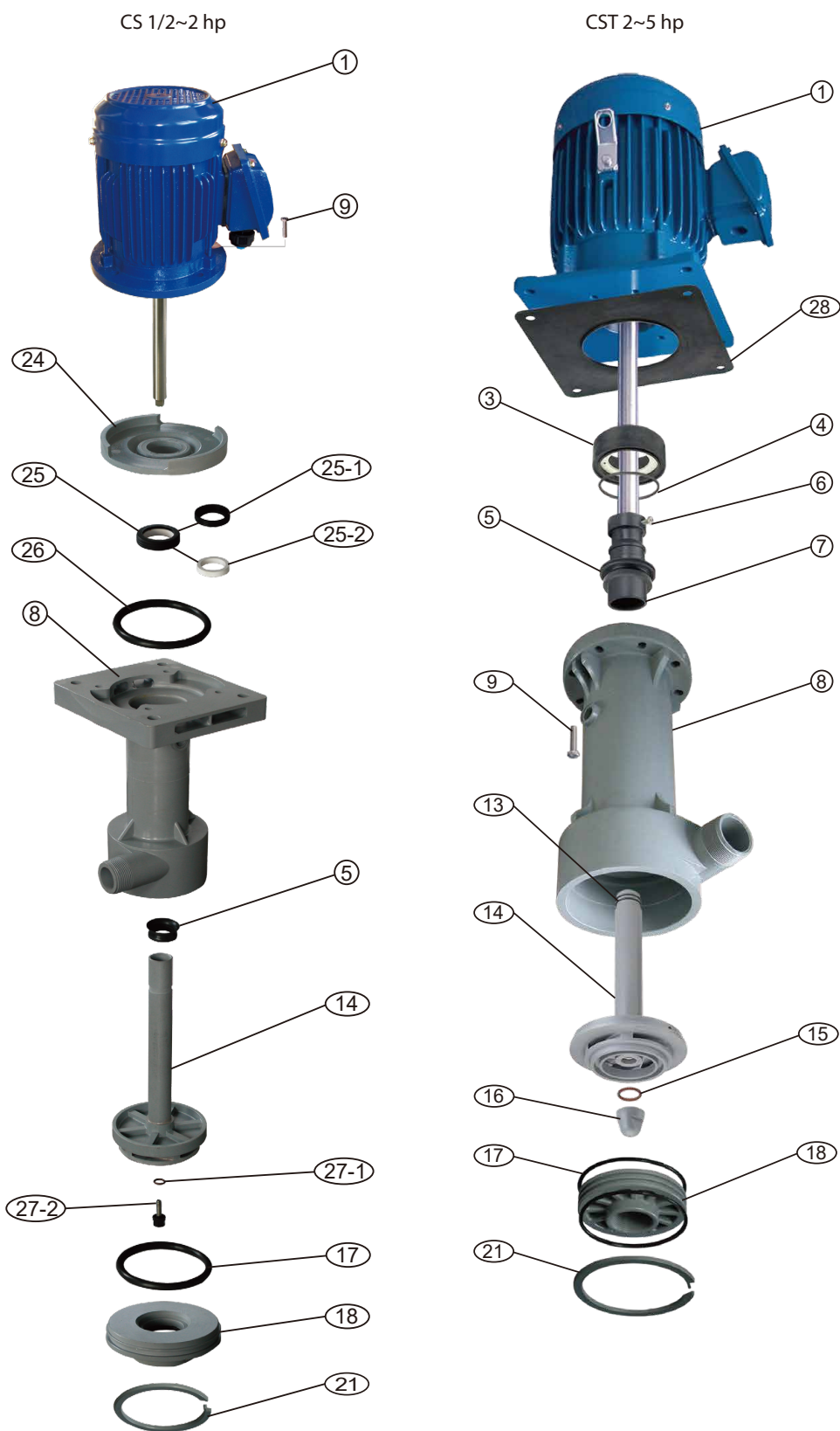

NO.	名称 Name	材质 Material	马力 Power
1	马达 Motor	FC	1/8~1/6 hp, 1/4~1/3 hp, 1/2~2 hp, 2-5 hp
3	CST轴封盖 Dry seal cover	FRPP/CPVC/PVDF	2~5 hp
4	CST轴封盖O环 Dry seal cover O-ring	NBR/VITON	2~5 hp
5	干式轴封 Dry seal	NBR/VITON	1/2~2 hp, 2~5 hp
6	轴套螺丝 Shaft sleeve screw	SUS	2~5 hp
7	轴套 Shaft sleeve	FRPP/CPVC/PVDF	2~5 hp
8	主体 Body	FRPP/CPVC/PVDF	1/8~1/6 hp, 1/4~1/3 hp, 1/2~2 hp, 2~5 hp
9	主体固定螺栓 Body bolt	SUS/Titanium	2~5 hp
13	叶轮O环 Impeller O-ring	NBR/VITON	2~5 hp
14	叶轮 Impeller	FRPP/CPVC/PVDF	1/8~1/6 hp, 1/4~1/3 hp, 1/2~2 hp, 2~5 hp
15	叶轮螺帽O环 Impeller nut O-ring	NBR/VITON	2~5 hp
16	叶轮螺帽 Impeller nut	FRPP/CPVC/PVDF	2~5 hp
17	前盖O环 Front cover O-ring	NBR/VITON/EPDM	1/8~1/6 hp, 1/4~1/3 hp, 1/2~2 hp, 2~5 hp
18	前盖 Front cover	FRPP/CPVC/PVDF	1/8~1/6 hp, 1/4~1/3 hp, 1/2~2 hp, 2~5 hp
21	C扣环 C-clip	FRPP/CPVC/PVDF	1/8~1/6 hp, 1/4~1/3 hp, 1/2~2 hp, 2~5 hp
24	轴封盖 Dry seal cover	FRPP/PVDF	1/2~2 hp
25	陶瓷固定环 Ceramic stationary ring	Ceramic/NBR	1/2~2 hp
25-1	陶瓷垫片 Ceramic gasket	NBR	1/2~2 hp
25-2	陶瓷 Ceramic	Ceramic	1/2~2 hp
26	CS轴封盖O环 Dry seal cover O-ring	NBR/VITON/EPDM	1/2~2 hp
27-1	叶轮螺丝O环 Impeller screw O-ring	NBR/VITON/EPDM	1/4~1/3 hp, 1/2~2 hp
27-2	叶轮固定螺丝 Impeller screw	PVDF	1/4~1/3 hp, 1/2~2 hp
28	马达前盖垫片 Motor flange packing	NBR	2~5 hp

性能曲线 Performance curve

CS

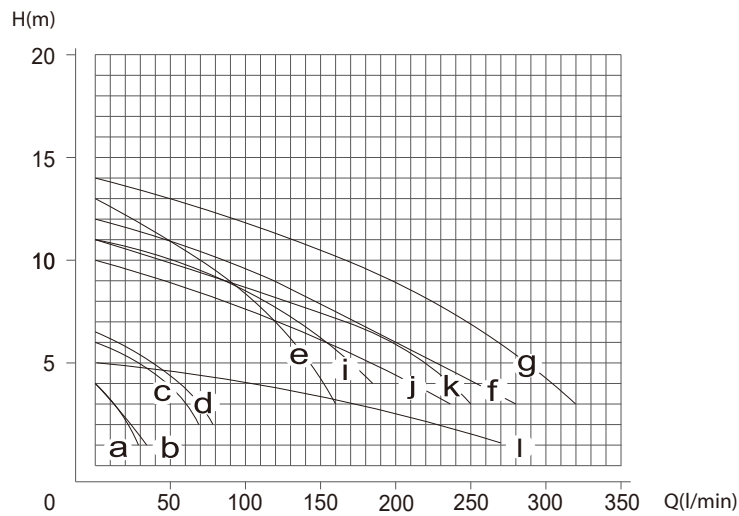

CST

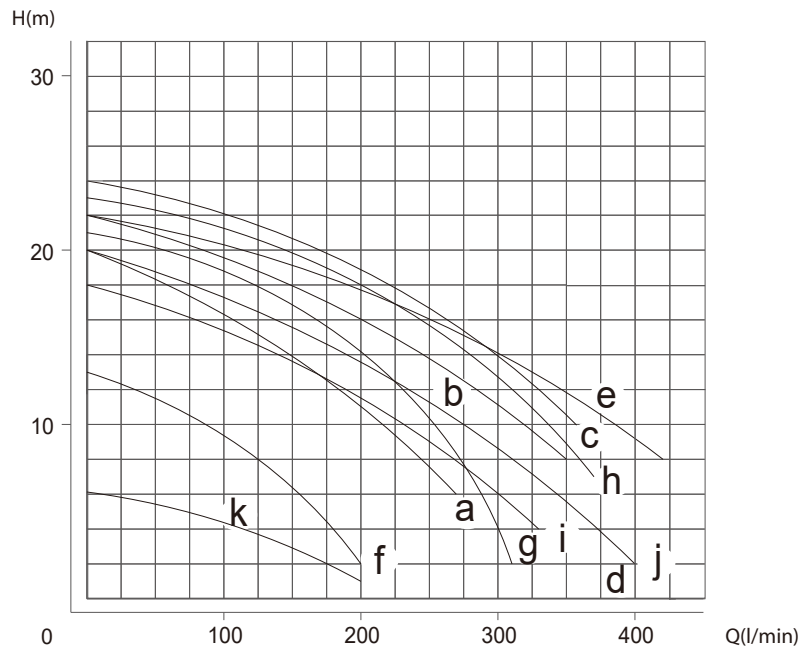

性能参数 Performance parameter

Testing Fluid: Water(Specific Gravity 1.0)

机型 Type	比重 S.G.	进出口径 In/outlet mm	相数 Phase	马力 Power hp	极数 Pole	曲线 Curve	全扬程 Max.head m	全流量 Max.flow l/min	重量 Weight kg
CS10.13-20L	1.1	25×20	1	1/8	2	a	4	28	6
CS10.17-20L	1.1	25×20	1	1/6	2	b	4	32	6
CS10.25-20L/CS30.25-20L	1.1	25×20	1Ø3Ø	1/4	2	c	6	70	14
CS10.33-25L/CS30.33-25L	1.1	25×25	1Ø3Ø	1/3	2	d	6.5	80	15
CS10.5-25L/CS30.5-25L	1.1	40×25	1Ø3Ø	1/2	2	e	13	160	19
CS11-40L/CS31-40L	1.1	50×40	1Ø3Ø	1	2	f	12	280	20
CS32-40L	1.1	50×40	3	2	2	g	14	320	24
CS10.17-20H	1.4	25×20	1	1/6	2	a	4	28	6
CS10.33-25H/CS30.33-25H	1.4	25×25	1Ø3Ø	1/3	2	c	6	70	15
CS11-25H/CS31-25H	1.4	40×25	1Ø3Ø	1	2	i	11	200	20
CS11-40H/CS31-40H	1.4	50×40	1Ø3Ø	1	2	j	10	230	19
CS32-40H	1.4	50×40	3	2	2	k	11	250	20
CS30.5-40H	1.4	50×40	3	1/2	4	l	5	270	20

Testing Fluid: Water(Specific Gravity 1.0)

机型 Type	比重 S.G.	进出口径 In/outlet mm	相数 Phase	马力 Power hp	极数 Pole	曲线 Curve	全扬程 Max.head m	全流量 Max.flow l/min	重量 Weight kg
CST32-40L	1.1	50×40	3	2	2	a	20	270	40
CST33-40L	1.1	50×40	3	3	2	b	22	350	43
CST35-40L	1.1	50×40	3	5	2	c	24	360	60
CST33-50L	1.1	50×50	3	3	2	d	20	400	44
CST35-50L	1.1	50×50	3	5	2	e	22	420	61
CST32-40H	1.4	50×40	3	2	2	f	13	200	40
CST33-40H	1.4	50×40	3	3	2	g	21	310	43
CST35-40H	1.4	50×40	3	5	2	h	23	370	60
CST33-50H	1.4	50×50	3	3	2	i	18	330	44
CST35-50H	1.4	50×50	3	5	2	j	20	400	61
CST31-50H	1.4	50×50	3	1	4	k	6.5	200	32



外形及安装尺寸 Installation dimensions

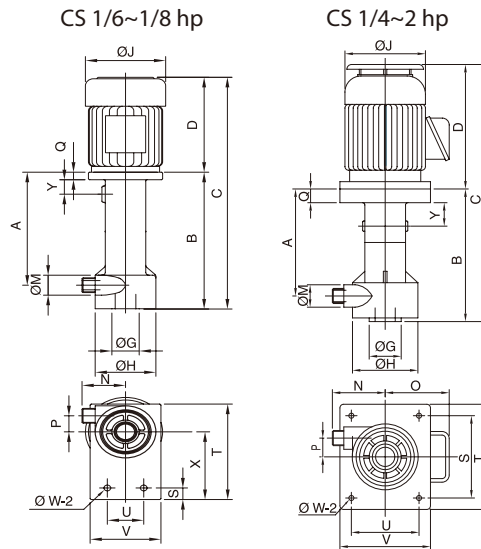

Unit:mm

Model	A	B	C	D	G	H	J	M	N	O	P	Q	S	T	U	V	W	X	Y
CS10.13-20L	195	236	401	165	40	90	128	33	64.5	-	30	14	20	165	54	109	10	117	36
CS10.17-20H(L)	195	236	401	165	40	90	128	33	64.5	-	30	14	20	165	54	109	10	117	36
CS10.25-20L/CS30.25-20L	260	302	562	260	42	110	154	43	100	142	35	18	150	182	150	182	10	-	53.5
CS10.33-25H(L)/CS30.33-25H(L)	260	302	562	260	42	110	154	43	100	142	35	18	150	182	150	182	10	-	53.5
CS10.5-25L/CS30.5-25L	234	293	578	285	70	144	187	49	115	153	41	30	180	230	150	198	15	-	30.5
CS11-25H/CS31-25H	234	293	578	285	70	144	187	49	115	153	41	30	180	230	150	198	15	-	30.5
CS11-40H(L)/CS31-40H(L)	234	293	578	285	70	144	187	49	115	153	41	30	180	230	150	198	15	-	30.5
CS32-40H(L)	234	293	608	315	70	144	187	49	115	153	41	30	180	230	150	198	15	-	30.5
CS30.5-40H	234	297	582	285	70	161	187	49	126	153	49	31	196	249	166	216	15	-	30.5

CST

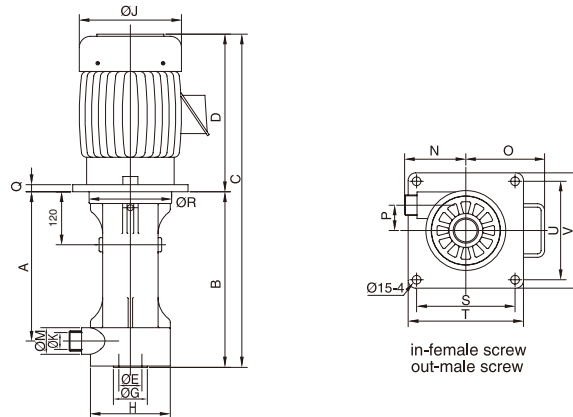

Unit:mm

Model	A	B	C	D	E	G	H	J	K	M	N	O	P	Q	R	S	T	U	V
CST32-40L	339	395	735	340	50	76	180	202	40	60	140	192	60	16	186	222	260	222	260
CST33-40L	339	395	735	340	50	76	180	202	40	60	140	192	60	16	186	222	260	222	260
CST35-40L	339	395	775	380	50	76	180	247	40	60	140	212	60	16	186	222	260	222	260
CST33-50L	339	395	735	340	50	76	180	202	50	60	140	192	60	16	186	222	260	222	260
CST35-50L	339	395	775	380	50	76	180	247	50	60	140	212	60	16	186	222	260	222	260
CST32-40H	339	395	735	340	50	76	180	202	40	60	140	192	60	16	186	222	260	222	260
CST33-40H	339	395	735	340	50	76	180	202	40	60	140	192	60	16	186	222	260	222	260
CST35-40H	339	395	775	380	50	76	180	247	40	60	140	212	60	16	186	222	260	222	260
CST33-50H	339	395	735	340	50	76	180	202	50	60	140	192	60	16	186	222	260	222	260
CST35-50H	339	395	775	380	50	76	180	247	50	60	140	212	60	16	186	222	260	222	260
CST31-50H	339	395	690	295	50	76	180	187	50	60	140	167	60	16	186	222	260	222	260

概述

CV/CVT泵性能可靠，泵浦运作时不会引入空气于所输送的液体，可广泛地应用于化学药水循环到加工模组等各种用途。泵浦轴心与叶轮用键组合，当泵浦逆转时，罩壳及叶轮也不会受损。即使泵浦空转也不会出现轴封或衬套损坏的问题。在CV/CVT泵浦座有通气槽，可防止化学药水渗透到马达座或轴承。

用途

- 化学药水或清水循环
- 废气处理
- 电镀

特点

- 无气泡立式泵。
- 最高流体温度：
SUS316 90 C (194 F), TI 95 C (203 F)
- 高效率，低操作成本，不泄漏，易于维护。
- 耐腐蚀性优。
- 配有持续重负载的TEFC马达。
- 1/2"厚安装板。
- 马达前后托架设计有油封，且泵体配有干式轴封，可防止酸气进入马达轴承。
- 突破性双叶轮设计。
- CVT钛金属泵浦，可耐特殊之化学药液，有1/2~2 hp等不同规格可供选择。

结构特点

- CV-316不锈钢；CVT-钛金属材料。
- 泵浦可槽内槽外安装，安装时一定要依安装高度之规定来操作。
- 泵头中没有轴封或轴承。
- 所有本公司三相电源的泵浦都有轴心键，当电源接反的时候，叶轮不会掉落，排除了可能对叶轮，罩壳及干式轴封的损坏。

General

CV/CVT pumps are with reliable performance, these pumps function without introducing air into the fluid which can sometimes destroy special chemical solutions. They are used in a wide range of applications, from chemical recirculation to process modules. The pump shaft incorporates a keyed lock to the impeller, when the pumps run in reverse, it will not damage the housing or impeller. There is no seal construction that can be damaged when the pumps run dry. CV/CVT pumps has a slotted air gap in the pump base, thereby preventing solution penetration to the motor base or bearings.

Applications

- Chemical or water recirculation
- Waste treatment
- Plating solutions

Features

- Airless vertical pumps.
- Max.fluid temperature:
SUS316 194 F(90 C), TI 203 F(95 C)
- High efficiency, low operating cost, no leakage operation and easy maintenance.
- Excellent chemical resistance.
- Adopt the continous heavy-duty TEFC motor.
- 1/2"thickness mounting plate.
- Both front and back sides of motor have oil seals to prevent acid vapor from entering the motor. Besides, extra dry seal can also stop the acid vapor to reach the bearing.
- Break-through double impellers design.
- CVT cast in titanium metal pump, suitable for special chemical liquid. The specification is 1/2~2 hp.

Construction features

- CV-316 stainless steel casting, CVT-titanium metal materic.
- Each in-tank and out-tank use are available.
- No seal or bearing construction.
- Each 3 phase power pump from GSD is with a keyed impeller shaft that eliminates the possibility of damage to the impeller, housing or dry seal when the power is reversed, the impeller will not fall off.



- 背叶轮设计可隔离泵浦在运转时因气体进入叶轮而产生的气泡，防止药水的氧化分解；提高背压，可防止液体在使用中上升而造成的溢流；突破性的设计模式，使背叶的反向阻力得到显著的提升，同时减少工作液体与空气的接触面积，减少空气溶解量，避免空气带入泵浦。
- 垫片采用橡胶外衬特氟龙垫片，使其耐腐蚀性、耐高温性得到显著提高。

- Patented rear impeller eliminates the bubble to enter the tank and destroy the solution. Increasing pressure from the rear impeller will stop the over flow in running. Break-through design of increasing the pressure from the rear impeller obviously as well as stops bubbles to mix with the fluid.
- Viton covered with teflon functions better in anti-corrosion and anti-heat.

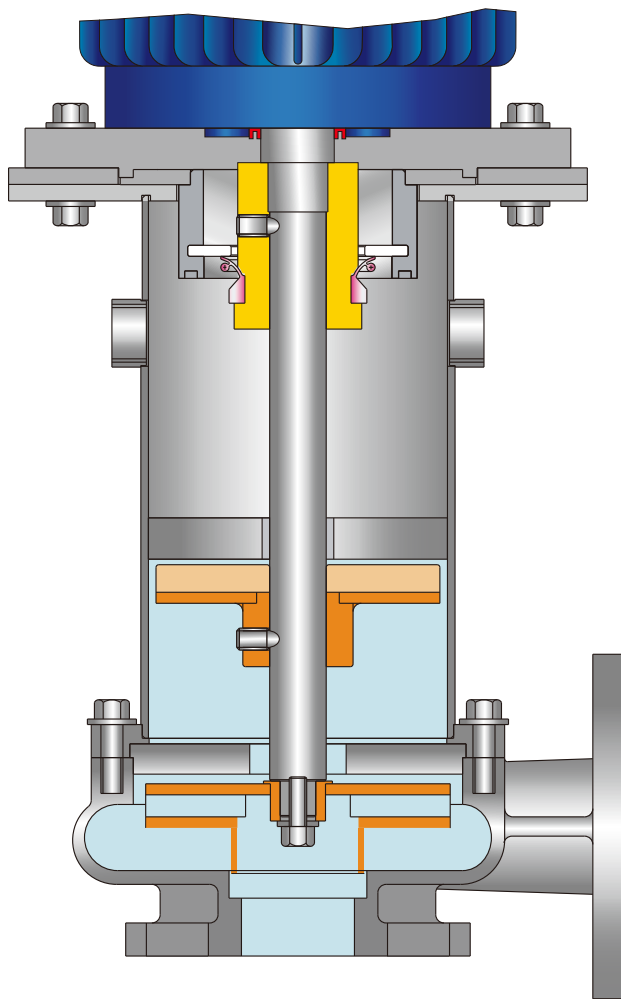

“创新型双叶轮设计” 原理 “Innovations of double-impellers design”

泵开始运转时，底部叶轮将液体逐步上推，待液体进入上部叶轮时，即受加大之背叶的强大阻力而无法上升，但上部叶轮所卷入液体中的空气，却受阻于水室中贮满的液体而无法下降，如此巧妙地排除了立式无轴封泵高压时溢流和大流量时吸入空气的两大难题，这种创新型的设计将引导世界的立式泵产业进入崭新的时代。

When pump starts, the lower impeller lifts the fluid up step by step. And the extreme centrifugal force from the enlarged higher impeller stops the fluid as it entering the higher impeller. At the same time, the full fluid in the chamber pump, overflow at high pressure and bubbles at big flow will not drain out. It solves the issues overflow and air suction. This innovations of double-impellers design will guide the vertical pump industry into a brand-new generation.

结构简图及材质 Construction and material

CV/CVT

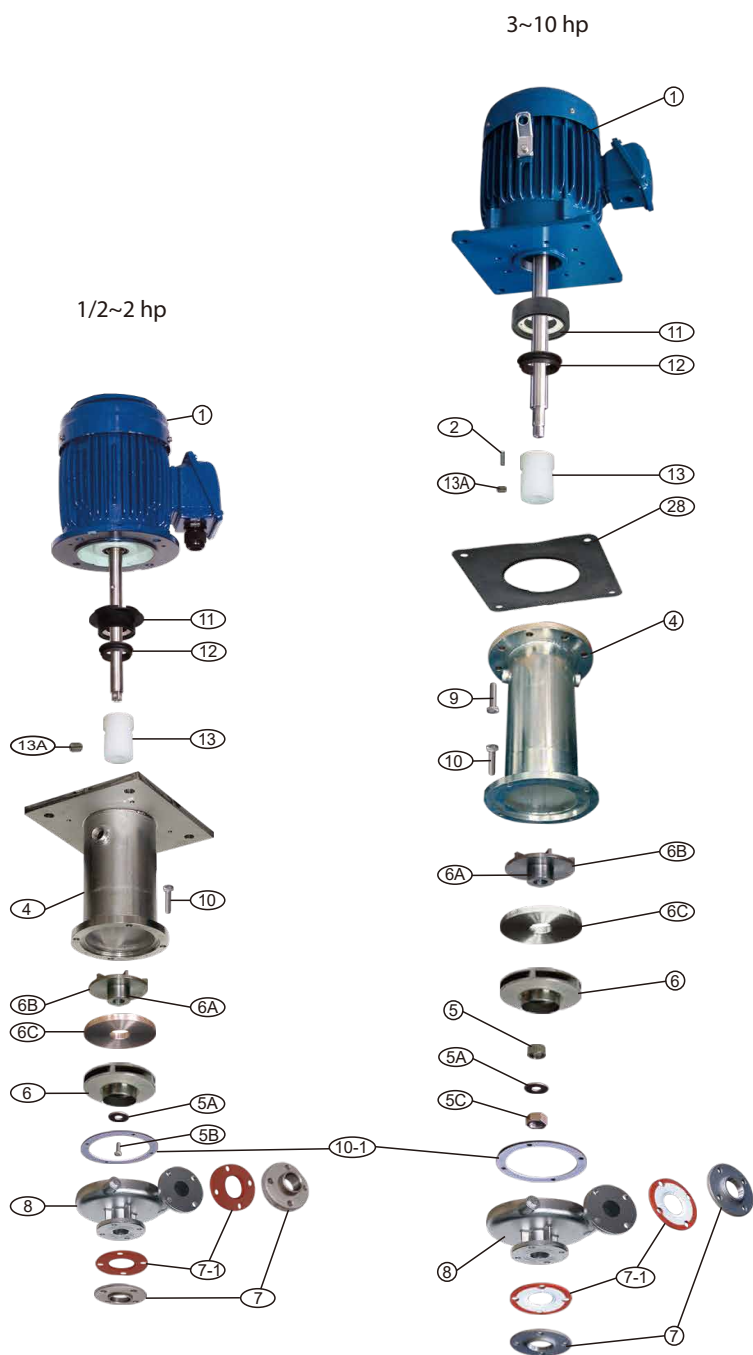

No.	名称 Name	材质 Material
1	马达 Motor	FC
2	轴心键 Shaft pin	SUS/Ti
4	主体 Body	SUS/Ti
5	间隔环 Spacer ring	SUS/Ti
5A	叶轮垫片 Impeller washer	SUS/Ti
5B	叶轮螺丝 Impeller screw	SUS/Ti
5C	叶轮螺母 Impeller nut	SUS/Ti
6	叶轮本体 Impeller	SUS/Ti
6A	背叶固定螺丝 Rear impeller screw	SUS/Ti
6B	背叶体 Rear impeller	SUS/Ti
6C	隔板 Partition	SUS/Ti
7	法兰 Flange	SUS
7-1	法兰垫片 Flange gasket	NBR/EPDM/VITON/TEFLON
8	前盖体 Front cover	SUS/Ti
9	主体螺丝 Body screw	SUS/Ti
10	前盖螺丝 Front cover screw	SUS/Ti
10-1	主体垫片 Body gasket	NBR/EPDM/VITON/TEFLON
11	轴封盖 Dry seal cover	FRPP/Ceramic
12	干式轴封 Dry seal	NBR/EPDM/VITON
13	轴套 Shaft sleeve	PP
13A	轴套螺丝 Shaft sleeve screw	SUS
28	马达前盖垫片 Motor front cover gasket	NBR



性能曲线 Performance curve

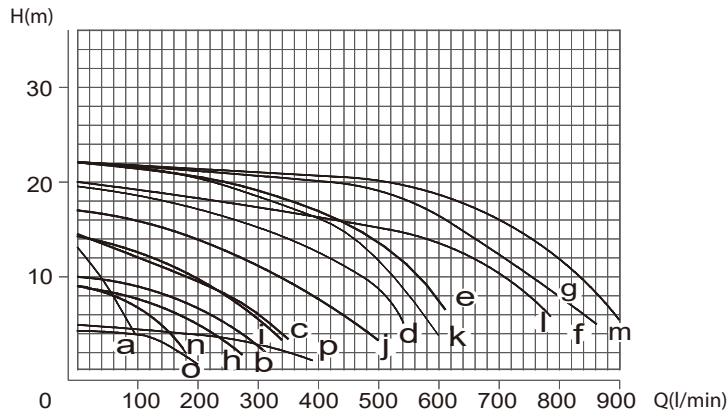

性能参数 Performance parameter

Testing Fluid: Water(Specific Gravity 1.0)

机型 Type	比重 S.G.	进出口径 In/outlet mm	相数 Phase	马力 Power hp	极数 Pole	曲线 Curve	全扬程 Max.head m	全流量 Max.flow l/min	重量 Weight kg
CV10.5-25L/CV30.5-25L	1.1	25×25	1Ø3Ø	1/2	2	a	13	95	26
CV11-40L/CV31-40L	1.1	40×40	1Ø3Ø	1	2	b	10	310	29
CV32-40L	1.1	40×40	3	2	2	c	14.5	350	32
CV33-50L	1.1	50×50	3	3	2	d	19.5	540	56
CV35-50L	1.1	50×50	3	5	2	e	22	600	72
CV37-65L	1.1	80×65	3	7.5	2	f	22	860	116
CV310-65L	1.1	80×65	3	10	2	f	22	860	122
CV11-40H/CV31-40H	1.4	40×40	1Ø3Ø	1	2	h	9	280	29
CV32-40H	1.4	40×40	3	2	2	i	14.5	340	32
CV33-50H	1.4	50×50	3	3	2	j	17	500	54
CV35-50H	1.4	50×50	3	5	2	k	22	600	72
CV37-65H	1.4	80×65	3	7.5	2	l	20	760	116
CV310-65H	1.4	80×65	3	10	2	m	22	920	122
CV30.5-40H	1.4	40×40	3	1/2	4	o	4.5	195	29
CV31-50H	1.4	50×50	3	1	4	p	5	390	45
CVT10.5-40L/CVT30.5-40L	1.1	40×40	1Ø3Ø	1/2	2	n	9	180	24
CVT11-40L/CVT31-40L	1.1	40×40	1Ø3Ø	1	2	b	10	310	27
CVT32-40L	1.1	40×40	3Ø	2	2	c	14.5	350	30

外形及安装尺寸 Installation dimensions

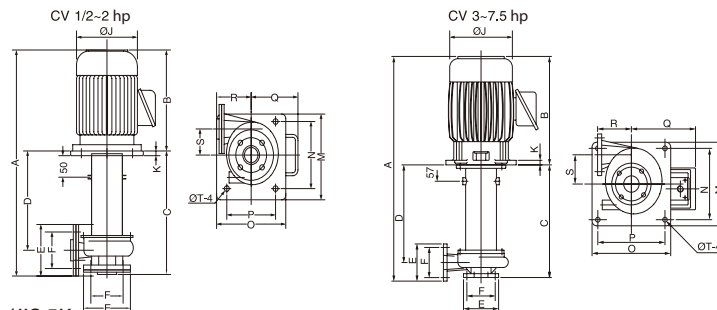

CV-IN/OUT-Female screw/JIS 5K

Unit:mm

Model	A	B	C	D	E	F	K	M	N	O	P	Q	R	S	T
CV10.5-25L/CV30.5-25L	542	242	300	235	78	64	12	230	180	210	148	142	117	60	15
CV11-40H(L)/CV31-40H(L)	552	242	310	247	118	92	12	230	180	210	148	142	135	73	15
CV32-40H(L)	585	275	310	247	118	92	12	230	180	210	148	142	135	73	15
CV33-50H(L)	733	340	393	340	130	103	16	260	222	260	222	192	133	90	15
CV35-50H(L)	773	380	393	340	130	103	16	260	222	260	222	212	133	90	15
CV37-65H(L)	856	440	416	343	175	127	20	350	300	350	300	250	161	95	18
CV310-65H(L)	856	440	416	343	175	127	20	350	300	350	300	250	161	95	18
CV30.5-40H/2P	552	242	310	247	118	92	12	230	180	210	148	142	135	73	15
CV30.5-40H/4P	552	242	310	247	118	92	12	230	180	210	148	142	135	73	15
CV31-50H	688	295	393	343	130	103	16	260	222	260	222	167	133	90	15
CVT10.5-40L/CVT30.5-40L	532	242	290	247	118	92	12	230	180	210	148	142	120	73	15
CVT11-40L/CVT31-40L/32-40L	565	275	290	247	118	92	12	230	180	210	148	142	120	73	15

概述

CWP泵性能可靠，泵浦运作时不会引入空气于所输送的液体，可广泛地应用于化学药水循环到加工模组等各种用途。泵浦轴心与叶轮用键组合，当泵浦逆转时，罩壳及叶轮也不会受损。即使泵浦空转也不会出现轴封或衬套损坏的问题。CWP泵浦座具有通气槽，可防止化学药水渗透到马达座或轴承。

用途

- 化学药水或清水循环
- 废气塔/废水处理
- 电镀
- 湿制程
- 净化溶液
- 各种酸液输送

特点

- 无气泡立式泵。
- 泵浦材质：FRPP
- 最高流体温度：FRPP 75 °C (167°F)
- 高效率，低操作成本，不泄漏，易于维护。
- 耐腐蚀性优。
- 配有持续重负载的TEFC马达。
- 泵浦空运转不会损坏干式轴封。
- 三相马达配有轴心键，可避免叶轮因马达逆转而损坏。

结构特点

- 槽内式安装，安装时一定要依安装高度之规定来操作。
- 泵头中没有轴封或轴承。
- 出口配管，安装容易。
- 马达前后托架设计有油封，且泵体配有干式轴封，可防止酸气进入马达轴承。
- 轴封运转时产生的摩擦热利用轴封陶瓷片来传热，该轴封陶瓷片采用高纯度氧化铝制成，耐磨、耐热、耐酸碱。
- 突破性的双干式轴封设计
 - *不会溢流
 - *不会反压漏液
 - *使药液中的酸气完全隔离，不会从轴封漏出

General

CWP pumps are with reliable performance, these pumps function without introducing air into the fluid which can sometimes destroy special chemical solutions. They are used in a wide range of applications, from chemical recirculation to process modules. The pump shaft incorporates a keyed lock to the impeller, when the pumps run in reverse, it will not damage the housing or impeller. There is no seal construction that can be damaged when the pumps run dry. CWP pumps has a slotted air gap in the pump base, thereby preventing solution penetration to the motor base or bearings.

Applications

- Chemical or water recirculation
- Fume scrubbers/waste treatment
- Plating solutions
- Wet processing
- Cleaning solutions
- Deliver acids

Features

- Airless vertical pumps.
- FRPP material.
- MAX.fluid temperature: FRPP 167°F(75 °C)
- High efficiency, low operating cost, no leakage operation and easy maintenance.
- Excellent chemical resistance.
- Adopt the continous heavy-duty TEFC motor .
- CWP pumps can run dry without damage to dry seal.
- Keyed impeller prevent damage if pumps run in reverse on all three phase motors.

Construction features

- In-tank use only.
- No seal or bearing construction.
- Discharge plumbing, easy mounting.
- Both flanges of moter have oil seals to prevent acid vapor from entering the motor. Besides, extra dry seal can also stop the acid vapor to reach the bearing.
- The heat caused by friction of dry seal sinks by way of seal plate which is made of high purity aluminum oxide. Excellent in wear-resisting, heat-resisting and chemicals resisting.
- Double dry seal design
 - *No overflow.
 - *No leakage caused by high pressure.
 - *No acid vapor ecapases from the vapor seals.



- 高强度叶轮片
采用嵌入、热熔接合，抗高压、高温，大大地改善以往熔接不良、脱离的缺点。
- 接合座
在其四周的排气孔，可以直视检测马达转动的方向，同时可避免可能溢流出的药水腐蚀马达，并排出有害的气体。
- 采用一体射出成型，强度高，可避免因焊接不良而产生的泄漏。接合处可配合客户需求选择由任式或法兰式。

- High Strength Impeller
Embedding and welding design make impeller much stronger than ever. It also improves pressure-resisting, heat-resisting functions and stops the impeller falling because of bed welding.
- Ventilator
Being able to check the rotating direction through the holes. They also functions to drain out the overflow fluid and vapor.
- One piece molding stronger and avoid leakage from bad welding. Union or flange is available for connection on request.

结构简图及材质 Construction and material

CWP

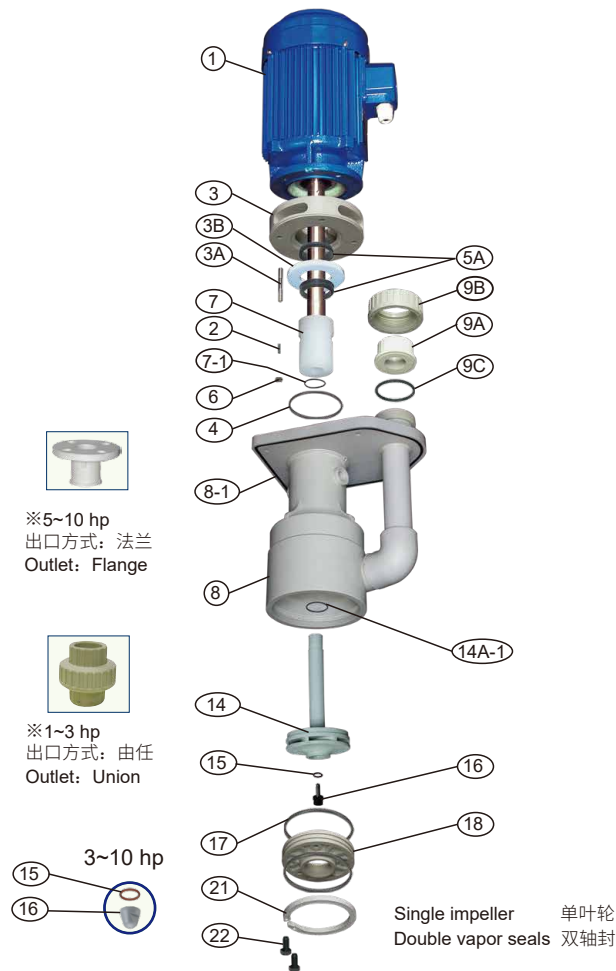

No.	名称 Name	材质 Material
1	马达 Motor	FC
2	轴心键 Shaft pin	SUS
3	接合座 Ventilator	FRPP
3A	接合座固定螺丝 Bolt	SUS
3B	陶瓷 Ceramic	Ceramic
4	陶瓷O环 Ceramic O-ring	NBR/VITON/EPDM
5A	干式轴封 Dry seal	EPDM/VITON
6	轴套螺丝 Shaft sleeve screw	SUS
7	轴套 Shaft sleeve	PP
7-1	轴套O环 Shaft sleeve O-ring	NBR/EPDM/VITON
8	主体 Body	FRPP
8-1	主体固定O环 Body O-ring	NBR/EPDM
9A	由任外特普 Union end	PP/PVC
9B	由任螺帽 Union cap	PP/PVC
9C	由任O环 Union O-ring	NBR/VITON/EPDM
14	叶轮体 Impeller	FRPP
14A	背叶轮 Rear impeller	FRPP
14A-1	叶轮O环 Impeller O-ring	NBR/VITON/EPDM
15	叶轮锁帽O环 Impeller nut O-ring	NBR/VITON/EPDM
16	叶轮固定螺丝 Impeller nut	PVDF/FRPP
17	前盖O环 Front cover O-ring	NBR/VITON/EPDM
18	前盖 Front cover	FRPP
21	前盖C扣环 Front cover C-clip	FRPP
22	C扣固定螺丝 C-clip nut	FRPP

性能曲线 Performance curve

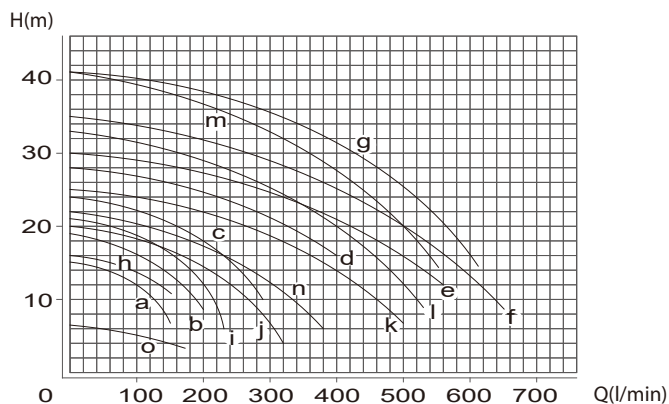

性能参数 Performance parameter

Testing Fluid: Water(Specific Gravity 1.0)

机型 Type	比重 S.G.	进出口径 In/outlet mm	相数 Phase	马力 Power hp	极数 Pole	曲线 Curve	全扬程 Max.head m	全流量 Max.flow l/min	重量 Weight kg
CWP30.5-25L	1.1	50×25	3∅	1/2	2	a	15.5	150	18
CWP31-25L	1.1	50×25	3∅	1	2	b	19	200	20
CWP32-25L	1.1	50×25	3∅	2	2	c	24	290	25
CWP32-32L	1.1	50×32	3∅	2	2	n	22	380	25
CWP33-32L	1.1	50×32	3∅	3	2	d	28	400	29
CWP31-32L	1.1	50×32	3∅	1	2	o	6.5	170	22
CWP35-40L	1.1	50×40	3∅	5	2	e	30	560	46
CWP37.5-50L	1.1	65×50	3∅	7.5	2	f	35	650	73
CWP310-50L	1.1	65×50	3∅	10	2	g	41	610	76
CWP31-25H	1.4	50×25	3∅	1	2	h	16	150	20
CWP32-25H	1.4	50×25	3∅	2	2	i	21	230	25
CWP33-32H	1.4	50×32	3∅	3	2	j	20	320	29
CWP35-40H	1.4	65×40	3∅	5	2	k	25	500	46
CWP37.5-50H	1.4	65×50	3∅	7.5	2	l	33	530	73
CWP310-50H	1.4	65×50	3∅	10	2	m	41	550	76

外形及安装尺寸 Installation dimensions

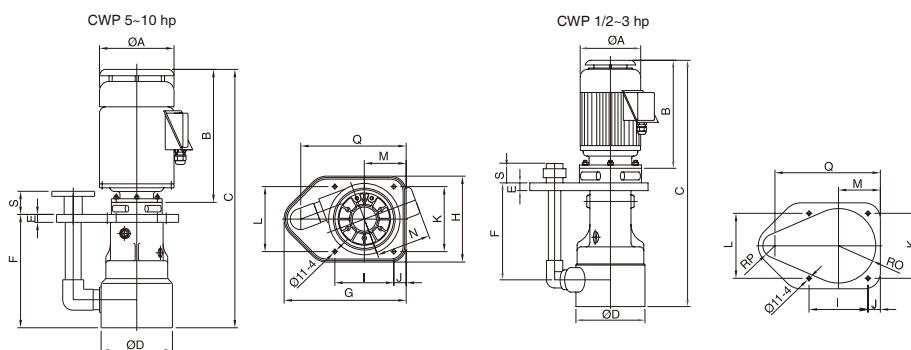

Unit:mm

Model	A	B	C	D	E	F	G	H	I	J	K	L	M	N	RO	RP	Q	S
CWP30.5-25L	157	280	637	178	25.5	295	341	240	211	26	180	180	117	125	94	25	260	70
CWP31-25H(L)	177	313	670	178	25.5	295	341	240	211	26	180	180	117	135	94	25	260	70
CWP32-25H(L)	197	344	701	178	25.5	295	341	240	211	26	180	180	117	145	94	25	260	70
CWP31-32L	177	313	670	178	25.5	295	341	240	211	26	180	180	117	145	94	32	275	80
CWP32-32L	197	344	701	178	25.5	295	341	240	211	26	180	180	117	145	94	32	275	80
CWP33-32H(L)	197	359	716	178	25.5	295	341	240	211	26	180	180	117	145	94	32	275	87
CWP35-40H(L)	250	420	825	225	25	338	385	271	186	39	205	205	132	172	118	32	322	40
CWP37.5-50H(L)	250	455	860	225	30	333	385	271	186	39	205	205	132	196	118	40	322	53
CWP310-50H(L)	250	485	890	225	30	333	385	271	186	39	205	205	132	196	118	40	322	53



概述

CD/CSD泵性能可靠，可广泛地应用于化学药水循环到加工模组等各种用途。即使泵浦空转也不会出现轴封或衬套损坏的问题。该泵浦可输送各种高腐蚀性的溶液，并根据选用的结构材质不同，可承受最高流体温度达75℃(167°F)到85℃(185°F)。CD/CSD泵在其泵浦座上均有一个干式轴封和一个排气槽，排气槽搭配顶部的干式轴封，可防止酸气渗透到马达轴承。泵浦轴心与叶轮用键组合，当泵浦逆转时，罩壳及叶轮也不会受损。

用途

- 化学药水或清水循环
- 废气塔/废水处理
- 电镀

特点

- 泵浦材质依化学性需求不同有FRPP、PVDF、CPVC可供选择。
- 最高流体温度：
FRPP/CPVC 75℃(167°F)，PVDF 85℃(185°F)
- 高效率，低操作成本，不泄漏，易于维护。
- 耐腐蚀性优良。（用于槽外）
- 配有持续重负载的TEFC马达。
- 泵浦空运转不会损坏干式轴封。
- 单干式轴封（CD）及双干式轴封（CSD）防止腐蚀性气体进入马达座。
- 泵浦座上有通气槽。
- 此种泵浦可安装于槽外或使用于加工模组中，当用于槽内式安装时应考虑其使用之化学性，更改其他材质的螺丝。

结构特点

- 泵头中没有轴封或轴承。
- 主体采用一体射出成型，强度高。
- 可更换不同规格的后盖和叶轮，从而时泵浦得到更高的输出功率。
- 所有本公司三相电源的泵浦都有轴心键，当电源反的时候，叶轮不会掉落，排除了可能对叶轮、罩壳及干式轴封的损坏。

General

CD/CSD pumps are with reliable performance, these pumps are used in a wide range of applications from chemical recirculation to process modules. There is no seal construction that can be damaged when the pumps run dry. CD/CSD pumps can deliver the maximum fluid temperature of 167°F(75℃) to 185°F(85℃), depending on the materials of construction, and can handle the most abrasive solution. They have a slotted air gap in the pump base and a double-dry seal, thereby preventing corrosive vapor from penetrating to the motor bearings. The pump shaft incorporates a keyed lock to the impeller, so when the pumps run in reverse the housing and the impeller will not be damaged.

Applications

- Chemical or water recirculation
- Fume scrubbers/waste treatment
- Plating solutions

Features

- CPVC, PVDF, or FRPP materials are on requests for different solutions.
- MAX.fluid temperature:
FRPP/CPVC 167°F(75℃), PVDF 185°F(85℃)
- High efficiency, low operating cost, no leakage operation and easy maintenance.
- Excellent chemical resistance. (Outside of the tank)
- Adopt the continuous heavy-duty TEFC motor .
- CD/CSD pumps can run dry without damage to dry seal.
- Single vapor seal of CD series or double seals of CSD pumps prevents corrosive vapors from entering the motor base.
- Air gap in pump base.
- The pump can be mounted outside of tank or process module. For mounted inside the tank, the bolts should be changed depending on the solution.

Construction features

- No seal or bearing construction.
- The one piece body construction imprpves the strength.
- Various replaceable covers and impellers are available for different performance.
- Each 3 phase power pump from GSD is with a keyed impeller shaft that eliminates the possibility of damage to the impeller, housing or dry seal when the power is reversed. The impeller will not fall off.

- 溢流接头可将停机时溢流的液体导回药水槽。
- CD泵开始运转时，干式轴封因离心力而打开，避免其磨损，泵浦停机时，轴封回复原位而闭锁，防止酸气或药水腐蚀轴承。
- CD泵超大型的叶轮外径，满足各种高压之应用场合的要求。
- CD泵嵌入式并多点热熔的叶轮一举克服了以焊条焊接之叶轮于高温、高压及高腐蚀性力的严苛工作条件下容易变形脱落的缺点。
- CSD双干式轴封设计，减少从顶部吸入之空气量，避免因反压而引起泄漏及防止药液中的酸气腐蚀轴承。

- CSD泵细心的散热式设计，主体有八个散热孔设计，可使运转中产生的热量自然排出，保护主体不受热变形。



- CSD机型具有大体积的陶瓷面，在长时间的运转摩擦时，可使摩擦热量经大面积的陶瓷散热。



- CSD嵌入式叶轮，搭配大量之固定柱，热熔密合，大大地提升了叶轮的牢固程度，可抗高温高压，不易损坏。
- CSD独特的超大型叶轮外径设计，当频率在50Hz时，其扬程可高于30m。

- CD/CSD独特的可换式组合后盖设计，当后盖内部磨损时，仅需更换式后盖即可，节省维修费用。



- The joint leads the overflow to the tank while shutting down the pump.
- The single dry seal of CD pump is opened by centrifugal force when pump is operating, it eliminates friction and seal wear. The seal closes back up when the pump shuts down to prevent vapor or fluid from reaching the motor face or bearings.
- The wide diameter of the impeller for CD pumps can meet the high pressure requirement for all kinds of applications.
- The impeller welded by weiding rod may deform or collapse in high temperature, pressure and strong corrosion applicatons. Embedded design eliminates this problem.
- CSD pumps' double dry seals design reducing the air from the top. No leakage caused by high pressure when the pump stops, and no acid vapor can reach the bearing.
- The heat dissipation design does prevent pump deformation. When pump operates, the heat will dissipate away the 8 holes.
- Enlarged ceramic sinks the seat caused by operation friction.
- Welded shores enable the impeller stronger for higher temperature and pressure applications.
- CSD pump is with unique wide impeller diameter. Head is higher than 30m while applied to frequency 50 Hz area.
- CD/CSD pumps' unique replaceable rear cover design, when the rear cover worn out, only changing the replaceable rear cover is enough.

结构简图及材质 Construction and material

CD

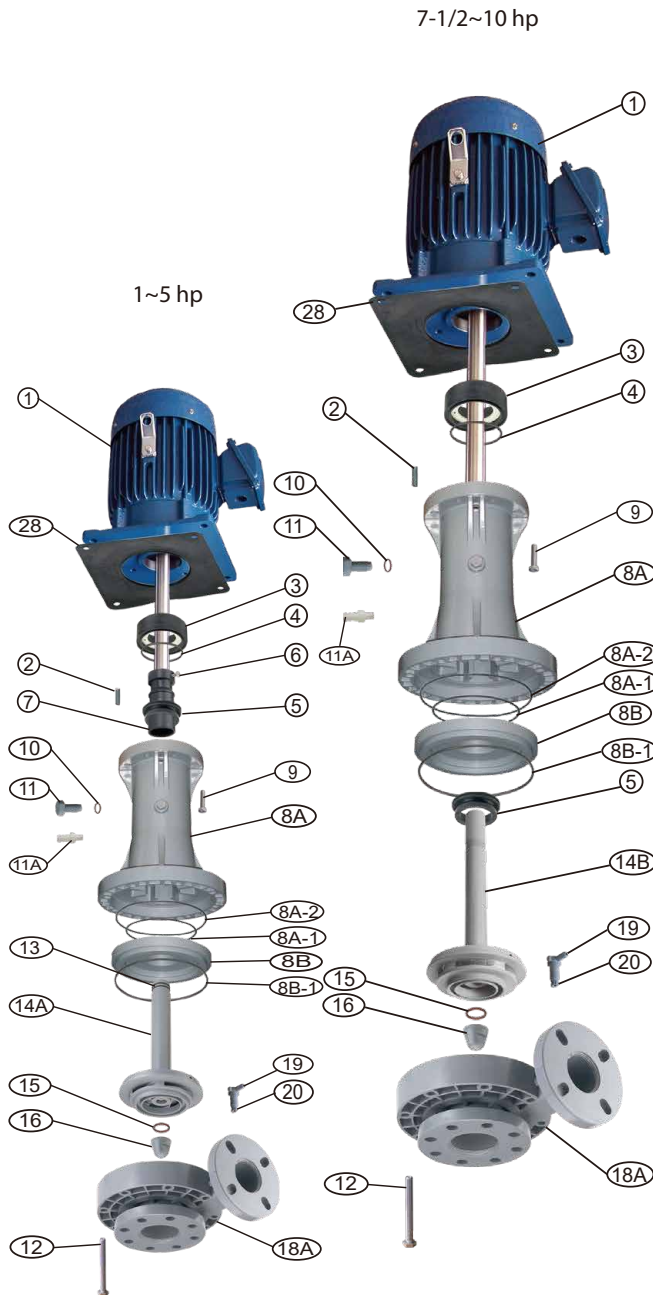

No.	名称 Name	材质 Material
1	马达 Motor	FC
2	轴心键 Shaft pin	SUS
3	轴封盖 Dry seal cover	FRPP
4	轴封盖O环 Dry seal cover O-ring	NBR/VITON/EPDM
5	干式轴封 Dry seal	NBR/VITON/EPDM
6	轴封螺丝 Shaft sleeve screw	SUS
7	轴套 Shaft sleeve	FRPP
8A	组合式主体 Body	FRPP/CPVC/PVDF
8A-1	主体后盖O环-1 Repaceable cover O-ring-1	NBR/VITON/EPDM
8A-2	主体后盖O环-2 Replaceable cover O-ring 2	NBR/VITON/EPDM
8B	主体后盖 replaceable cover	FRPP/CPVC/PVDF
8B-1	前盖O环 Front cover o-ring	NBR/VITON/EPDM
9	主体固定螺丝 Body bolt	SUS/Titanium
10	排放螺丝O环 Release screw O-ring	NBR/VITON
11	排放螺丝 Release screw	FRPP/CPVC/PVDF
11A	溢流接头 Iver flow jiont	PP/PVC
12	前盖螺丝 Front cover bolt	SUS/Titanium
13	叶轮O环 Impeller O-ring	NBR/VITON/EPDM
14A/B	叶轮 Impeller	FRPP/CPVC/PVDF
15	叶轮螺帽O环 Impeller nut O-ring	NBR/VITON/EPDM
16	叶轮螺帽 Impeller nut	FRPP/CPVC/PVDF
18A	前盖 Front cover	FRPP/CPVC/PVDF
19	排气阀 Air release valve	FRPP/CPVC/PVDF
20	排气阀垫片 Air release valve packing	NBR/VITON/EPDM
28	马达前托橡胶衬套 Motor flange packing	NBR

结构简图及材质 Construction and material

CSD

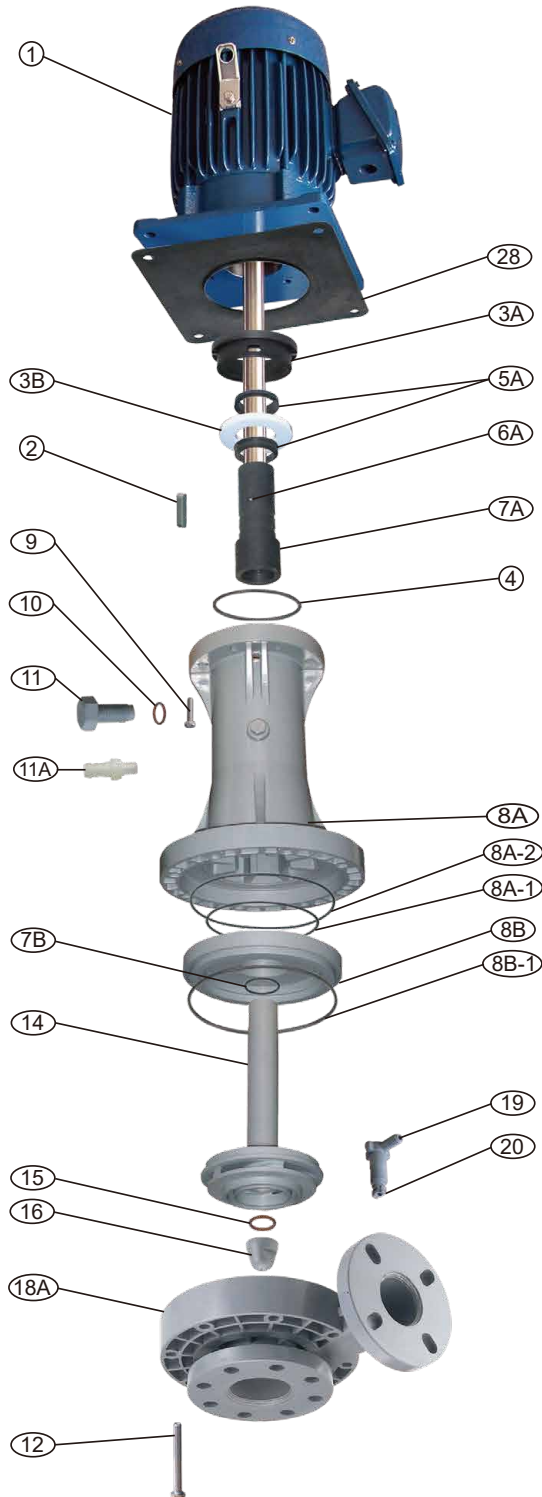

No.	名称 Name	材质 Material
1	马达 Motor	FC
2	轴心键 Shaft pin	SUS
3A	轴封盖 Dry seal cover	FRPP
3B	陶瓷 Ceramic	Ceramic
4	轴封盖O环 Dry seal cover o-ring	NBR/VITON/EPDM
5A	干式轴封 Dry seal	NBR/VITON/EPDM
6A	轴套固定螺丝 Shaft sleeve screw	SUS
7A	轴套 Shaft sleeve	FRPP
7B	轴套O环 Shaft sleeve o-ring	NBR/VITON/EPDM
8A	组合式主体 Body	FRPP/CPVC/PVDF
8A-1	主体后盖O环-1 Replaceable cover o-ring-1	NBR/VITON/EPDM
8A-2	主体后盖O环-2 Replaceable cover o-ring-2	NBR/VITON/EPDM
8B	主体后盖 Replaceable cover	FRPP/CPVC/PVDF
8B-1	前盖O环 Front cover o-ring	NBR/VITON/EPDM
9	主体固定螺丝 Body bolt	SUS/Titanium
10	排放螺丝O环 Release screw o-ring	NBR/VITON/EPDM
11	排放螺丝 Release screw	FRPP/CPVC/PVDF
11A	溢流接头 Over flow joint	PP/PVC
12	前盖螺栓 Front cover bolt	SUS/Titanium
14	叶轮 Impeller	FRPP/CPVC/PVDF
15	叶轮螺帽O环 Impeller nut o-ring	NBR/VITON/EPDM
16	叶轮螺帽 Impeller nut	FRPP/CPVC/PVDF
18A	前盖 Front cover	FRPP/CPVC/PVDF
19	排气阀 Air release valve	FRPP/CPVC/PVDF
20	排气阀垫片 Air release valve packing	NBR/VITON/TEFLON
28	马达前托橡胶衬套垫 Motor flange packing	NBR

性能曲线 Performance curve

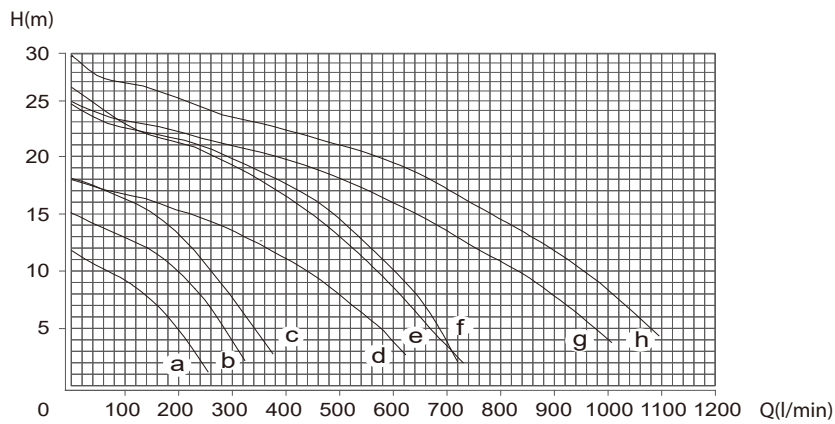

性能参数 Performance parameter

Testing Fluid: Water(Specific Gravity 1.0)

机型 Type	比重 S.G.	进出口径 In/outlet mm	相数 Phase	马力 Power hp	极数 Pole	曲线 Curve	全扬程 Head m	全流量 flow l/min	重量 Weight kg
CD31-40L	1.1	50×40	3	1	2	a	11.8	250	29
CD32-40L	1.1	50×40	3	2	2	b	15.1	325	38
CD33-40L	1.1	50×40	3	3	2	c	18.0	370	41
CD33-50L	1.1	65×50	3	3	2	d	18.0	620	41
CD35-50L/CSD35-50L	1.1	65×50	3	5	2	e	26.2	730	55
CD35-65L/CSD35-65L	1.1	80×65	3	5	2	f	24.8	720	55
CD37-65L/CSD37-65L	1.1	80×65	3	7.5	2	g	25.0	1000	95
CD310-65L/CSD310-65L	1.1	80×65	3	10	2	h	30.0	1100	106

外形及安装尺寸 Installation dimensions

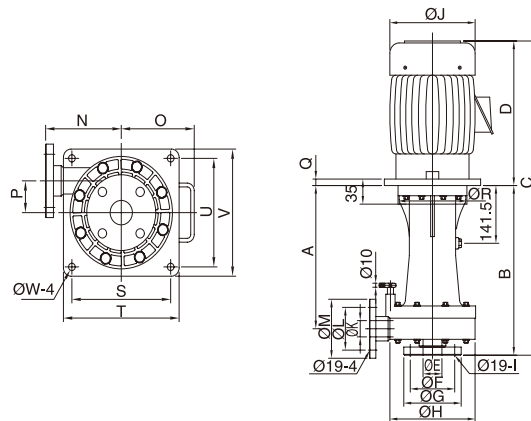

Unit:mm

Model	A	B	C	D	E	F	G	H	I	J	K	L	M	N	O	P	Q	R	S	T	U	V	W
CD31-40L	350	425	720	295	50	120	155	230	4	187	40	105	145	170	167	65	16	186	222	260	222	260	15
CD32-40L	350	425	765	340	50	120	155	230	4	202	40	105	145	170	192	65	16	186	222	260	222	260	15
CD33-40L	350	425	765	340	50	120	155	230	4	202	40	105	145	170	192	65	16	186	222	260	222	260	15
CD33-50L	350	425	765	340	65	140	177	260	4	202	50	120	155	200	192	65	16	186	222	260	222	260	15
CD/CSD35-50L	350	425	805	380	65	140	177	260	4	247	50	120	155	200	212	65	16	186	222	260	222	260	15
CD/CSD35-65L	350	425	805	380	78	150	190	260	8	247	65	140	177	200	212	65	16	186	222	260	222	260	15
CD/CSD37-65L	350	425	865	440	78	150	190	260	8	282	65	140	177	200	250	65	20	186	300	350	300	350	18
CD/CSD310-65L	350	425	865	440	78	150	190	260	8	282	65	140	177	200	250	65	20	186	300	350	300	350	18

使用范例 Examples

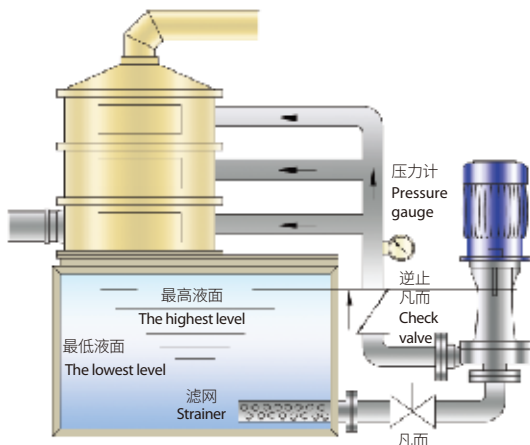
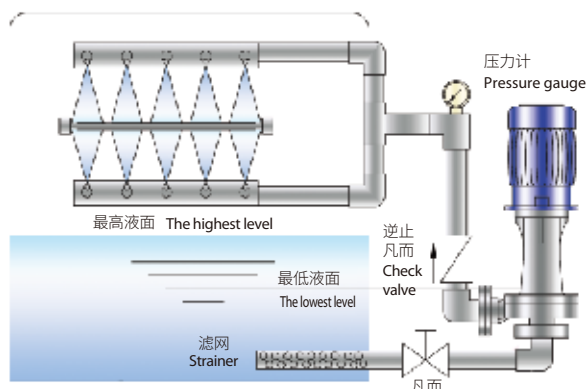
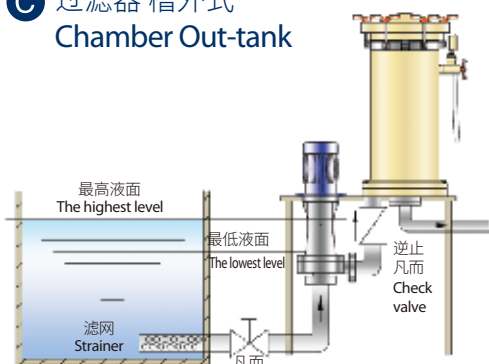
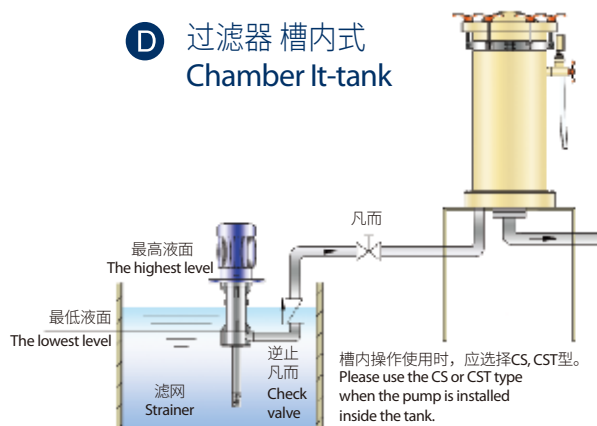
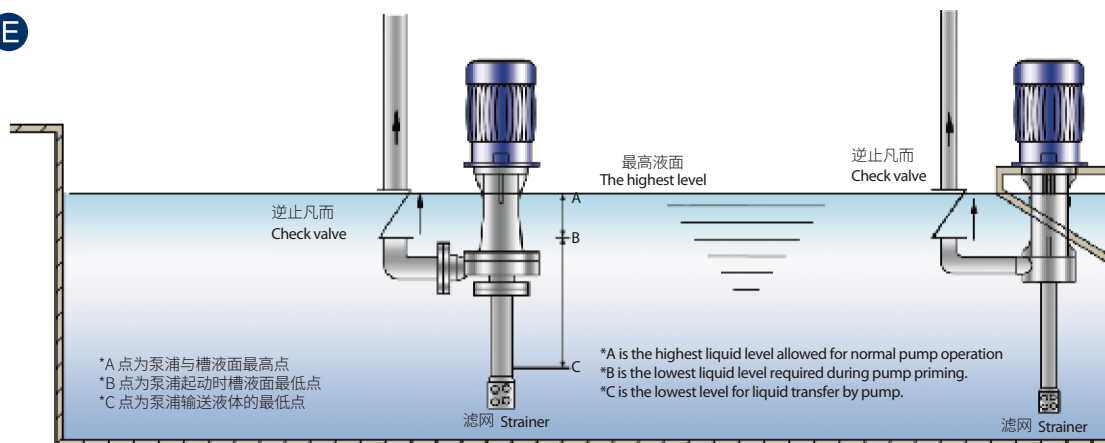
A 废气塔
Scrubber**B** PCB 蚀刻
PCB Etching**C** 过滤器 槽外式
Chamber Out-tank**D** 过滤器 槽内式
Chamber In-tank**E**

注意事项:









1. 出口配管高度, 如有高达马达以上或有逆压之情形时, 请在泵浦出口处装置逆止阀, 装置请勿超过最高液面线太高。
2. 入口处为安全起见, 最好装置过滤网以免吸入杂物损坏泵浦。(滤网面积为入口管截面积5倍以上)
3. 在特殊环境下使用时, 如需安装防爆或耐压防爆之马达时, 请与本公司技术人员商谈。
4. 在含有化学气体之环境下使用时, 必需选择特殊处理有防锈漆之马达。

Cautions:

1. Set a check valve at outlet of the pump if the outlet pipeline is higher than the pump and may cause back flow. Do not put the check valve higher than the highest liquid level in tank too much.
2. Set a strainer at the end of inlet to keep the pump from being damaged by impurities. (The total area of the strainer should be more than 5 times of the suction size.)
3. Please contact our technician if any special demand required. For example, anti-explosion motor.
4. Motor should be anti-corrosion coated for special corrodent environment.

欢迎索取以下产品型录

To find out more about following products, please visit www.gsd.net.cn

	泵系列 Pump Series	潜水泵系列 陆上泵系列 特种泵系列 Submersible pump series On land pump series Special pump series
	搅拌推流系列 Mixing and flow propeller	搅拌机系列 推流器系列 Mixing series Flow propeller series
	供氧曝气系列 Aeration equipment series	曝气机系列 曝气盘系列 曝气管系列 Aerator series Disc diffusers Tube diffusers
	风机系列 Blower Series	磁悬浮鼓风机 空气悬浮鼓风机 三叶罗茨鼓风机系列 Maglev turbo blower Turbo blower Three-lobe Roots Blower blower series
	污泥处理设备 Sludge treatment equipment	带式脱水机 厢式压滤机 叠螺式脱水机 污泥干化设备 浅层高效气浮设备 Belt filter press Box filter press Screw press Mud scraper Dissolved air flotation clarifier
	智能化系列 Intelligent series	智能设备 水务设备健康管理 水务系统工艺优化智联管理 Intelligent equipment Health management for water equipment Intelligent management for water system process
	反应器及套装设备 Reactor and package equipment	芬顿反应系统 MBR生物膜反应器 预制泵站 一体化污水处理设备 Fenton reaction system MBR biofilm reactor Prefabricated pumping station Intelligent Compact Unit
	耗材药剂及相关设备 Consumables, reagents and related equipment	生物绳 PAC 聚合氯化铝 PAM 聚丙烯酰胺 泡药设备 Biological rope PAC polyaluminum chloride PAM polyacrylamide Automatic dispensing dissolvers

GSD 的经营理念 Business Philosophy

G-Green 绿色 S-Safe 安全 D-Development 永续经营



川源(中国)机械有限公司
GSD (China) Co., Ltd.

水处理系统专业合作伙伴

Professional partners in water treatment systems

免费咨询电话

400-657-9066

川源(中国)机械有限公司版权所有 all rights reserved. CY-4A

数据来源: 公司实验室数据及客户实际使用数据, 具体使用环境不同, 数据可能存在差异。本型录内容如有变更, 恕不另行通知。

The data on the brochure is based on the laboratory testing data and customers' actual operation data in the past. The actual data may be different in different application conditions. We reserve the right to change content without notice.



马力

Power

hp